

*PistenBully*<sup>®</sup>

100 SCR

## PistenBully 100 SCR

The multi-talent for cross-country, slope and indoor preparation



*PistenBully*<sup>®</sup>

# Quality Made in Germany

A PistenBully is and remains something special. It encompasses new ideas, technologies and improvements that make it an efficient, safe and user-friendly partner on the slopes. You can rely on the quality of our products made in Germany. And on the fact that sustainability and a responsible approach to people, the environment and resources are an integral part of our philosophy. We use this philosophy to manufacture vehicles that have a concentrated charge of passion and innovation.

As a result, a PistenBully doesn't just do its job. It impresses! That is and remains our standard.



Jens Rottmair  
Chief Executive Officer



Michael Kuhn  
Head of Development

Jens Rottmair  
Chief Executive Officer





**CREATE THE  
CONDITIONS FOR  
A GREAT DAY!**



# PistenBully 100 SCR

## The multi-talent for cross-country, slope and indoor preparation

The PistenBully 100 SCR demonstrates its strengths on different terrains. It effortlessly prepares cross-country ski tracks, small slopes, winter hiking trails, drag lift or sledge tracks and snowmobile trails. The multi-talent creates optimum conditions for winter sports – and can also do so as an indoor vehicle in snow domes.

The PistenBully 100 SCR's multi-functional capability is due to its modular design. With different vehicle widths, a universal interface for attachments and diverse accessories, it adapts precisely to individual requirements.

### **NEW** Environmentally-friendly motorisation

Thanks to the introduction of the SCR technology, the PistenBully 100 SCR produces 90 % fewer emissions. The reduction in nitrogen emissions and fine dust particles is effected in a downstream SCR catalytic converter. The vehicle complies with the strict Tier 4i exhaust emission regulations. You'll find more information on the engine on page 10/11.

### **NEW** More power with lower engine speed

The full 150 kW of power now makes itself felt much earlier. The engine is more responsive at a lower speed and this also helps with improved steering and drive behaviour.

### **NEW** Improved climbing ability thanks to 4th running axle

An additional fourth running axle now offers even greater track contact surface. This has improved grip and climbing ability. The resulting improved smoothness and weight distribution also tangibly increases ride comfort and drive performance.

### **NEW** Ergonomically comfortable workstation

A satisfied driver does the best job. We place a lot of value on getting the workstation right. PistenBully pilots now sit in a much quieter space thanks to reduced noise. The two-seater driver's cab is spacious, clearly arranged and perfectly designed for easy handling. Many other details like the ergonomic steering wheel with joystick, the heated windows and windscreen wipers, cellphone holder, USB connection and the air-sprung driver's seat make the driver's working day that little bit easier.

### **Tested at major Nordic events**

For years, numerous organisations of international Nordic competitions have been placing their trust in the reliability of the PistenBully 100. The PistenBully 100 is now the world's best-selling track setter and is ideal for competitions and leisure work alike.



6

## All-Way-Blade

### High flexibility and precise work

#### ⦿ High flexibility and ideal roll behaviour

The All-Way-Blade provides the greatest flexibility (2.7 m or 3.1 m wide). Optimised, sensitive blade steering and ergonomic controls facilitate precise and yet relaxed work. The special roll crown on the blade and the extremely well-balanced vehicle geometry as a whole create the best roll characteristics in the snow.

#### ⦿ Variability and fast accessory changing

The one-person quick-change system makes it easy to change the front attachments, such as a front-snow blower (see page 15).



## Snow tiller

### Perfect grooming even in extreme conditions

#### ⦿ Excellent cutting teeth and design available in 3 different widths

We offer the snow tiller in three different working widths as a rear attachment. It is ideal for all applications – for grooming small slopes, lift terraces, winter hiking trails, in snow domes, but especially for cross-country tracks in the competition and leisure sector.





## Track setters

### Precise tracks for every scenario.

🔗 **Extensive selection of track setters for every scenario:**  
The PistenBully 100 SCR proves its particular strength and flexibility in perfect track setting for cross-country tracks in the competition and leisure sector – whether this be for classic cross-country tracks or skating tracks (see page 17).

Ski resort operators praise the high flexibility, the precision and the low maintenance requirement.

## PistenBully 100 Indoor

### Light-weight and agile in snow domes

The PistenBully 100 Indoor is the ideal vehicle for use in snow domes: The engine is quiet and also low-emission thanks to its integrated emission control and a soot filter. As an indoor specialist it impresses due to its agility in elongated snow domes and the greatest possible sensitivity in the snow.



# Cockpit

## A workstation that sets standards

The PistenBully 100 SCR is not inferior to its "brothers", the PistenBully 400 and the PistenBully 600, in any way in terms of comfort or handling.

Multiple features make the PistenBully 100 SCR a coveted workstation: The two-person driver's cab is generously sized. The air-sprung seat, the adjustable armrest, the ergonomic joystick and steering wheel create a working environment that prevents fatigue. Large, heated front, rear and side windows provide a clear view of the track, which is illuminated at night by LED and halogen lights. The machine is now even easier to use and is capable of more precise work thanks to the refined electrics for controlling the tillers and the track setters, and a tiller depth display. The other standard comfort equipment on the PistenBully 100 SCR includes a mobile phone holder, radio with USB port, and heated windscreen wipers.

### ⊕ Improved ergonomics

- Air-sprung, ergonomic driver's seat
- Universal, ergonomic joystick
- Clearly arranged display of all information

### ⊕ Safety

- ROPS-certified cab (7,5-tonne roof load)

### ⊕ More comfort, more function

- Heated cab with optimised ventilation system for a pleasant working environment
- Large, heated windows for the best all-round visibility
- Up to 6 dB lower noise level
- Anti-slip and breathable seat covers



Continuously adjustable semi-circular steering wheel.



All important functions are integrated into the ergonomically designed joystick.



The armrest supports the arm and contributes to effortless operation of the front and rear attachments.

Online:  
Virtual  
cockpit



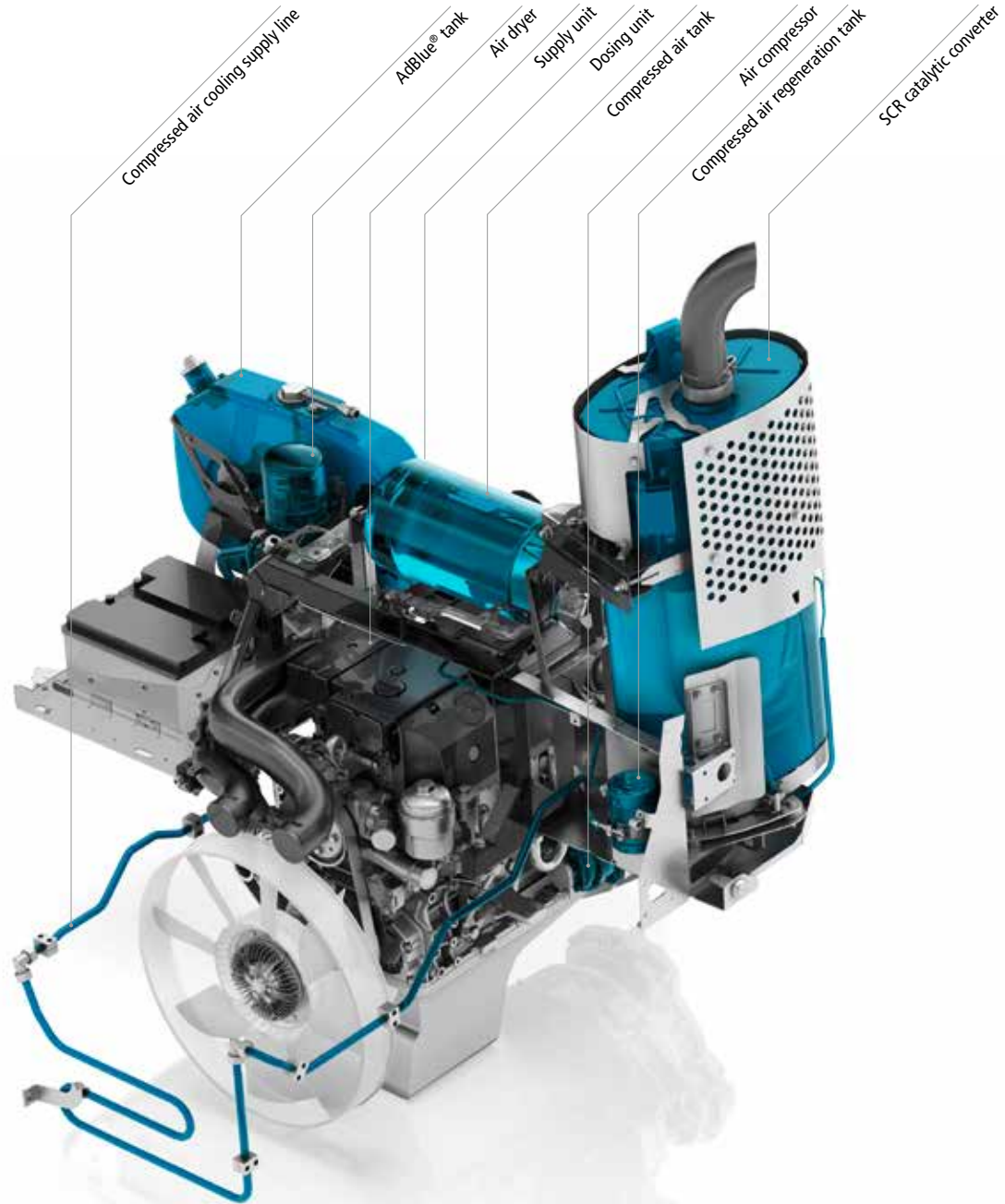

Online:  
virtual  
engine



# 100 SCR engine

## A powerful engine for cost-effective peak performance with low emissions

### ⦿ More power, more dynamic and 90 % fewer emissions!

With the new engine in the 100 SCR we have achieved several goals simultaneously: Increased performance thanks to the refined Mercedes engine, more dynamic power development thanks to higher torque at lower engine speeds, less consumption and not least the up to 90 % reduction in CO<sub>2</sub> emissions.

### ⦿ SCR – Selective Catalytic Reduction

The SCR technology primarily reduces the nitrogen oxide (NO<sub>x</sub>) in the exhaust gases. However, this largely suppresses unwanted side reactions (e.g. the oxidation of sulphur oxide into sulphur trioxide). This occurs because of "AdBlue®", an ammonia solution in a separate tank, which is mixed with the exhaust gas after combustion. The chemical reaction converts the ammonia and nitrogen oxide into harmless nitrogen and water. The emission of fine dust particles is also substantially reduced by this process.

### ⦿ Compliant with the new Tier 4i exhaust regulations.

The Mercedes-Benz OM 924 LA engine with SCR technology reduces the emission of fuel gases – particularly nitrogen oxide – and complies with the Tier 4i exhaust emission regulations that have been in place since 2011.

### Technical data

Type	Mercedes Benz OM 924 LA
Cylinders	4
Cubic capacity	4.80 l / 4,800 ccm
Power output (ECE)	150 kW (204 hp) at 2,200 rpm
Max. torque	800 Nm at 1,200 – 1,600 rpm
Fuel consumption	from 8.5 l/h
Tank capacity diesel	150 l
Tank capacity AdBlue®	25 l
Emission standard	Tier 4i

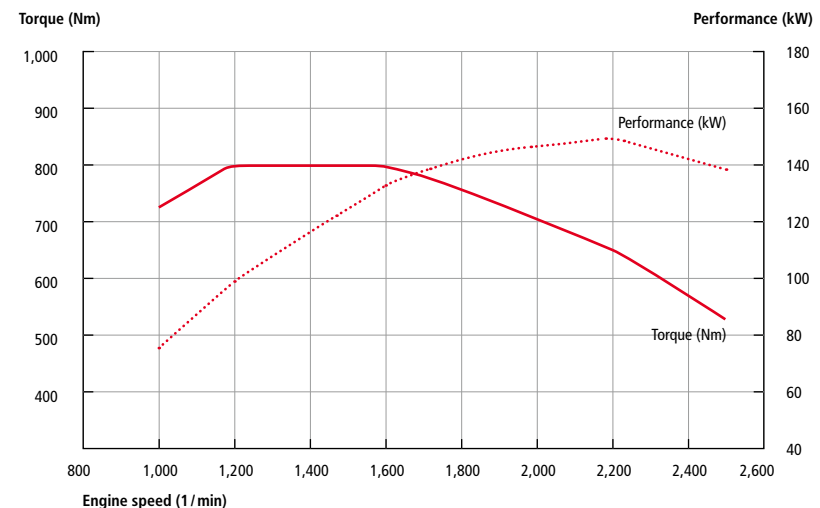





# Equipment for the PistenBully 100 SCR

## Standard



### Joystick

All important functions are integrated in the ergonomic joystick.



### LED working lights

The LED Powerbeam 1000 working lights provide perfect illumination of the working area to the front and rear in combination with the additional halogen lights.



### Air-sprung driver's seat

The ergonomic seat ensures work does not wear you out. It can be adjusted individually to the driver.

14

## Optional



### Technical package

The PistenBully can be supplemented with other hydraulically operated attachments, such as the front-snow blower using an additional high-pressure connection on the front of the vehicle.



### Solid tyres

Solid tyres, which last far longer, are available as an alternative to pneumatic tyres.



### Brush-guards

The brush-guards protect the windscreen and lights from branch damage.



# Original attachments

## 100 percent PistenBully quality

PistenBully original attachments don't have an outstanding reputation for nothing. You can rely on the fact that you're getting Made in Germany quality and the usual customer-oriented service.

Naturally, we have combined attachments and vehicle components in the best possible way so that everything works perfectly. And last but not least: we know the business and our products and are happy to support and advise you.

### Front attachments



#### SnowCutter

The SnowCutter is a special tool for breaking up particularly icy sections of snow. This drastically improves the finished quality in conjunction with the snow tiller.



#### Front-snow blower

Front-snow blower specially developed for the PistenBully for clearing car parks, roads and open areas. Also suitable for moving snow on the slopes.

### Superstructures



#### Cab 5 pers. / 700 kg

Cab for moving up to 5 people with foldaway bench



#### Cab 8 pers. / 750 kg

Cab for moving up to 8 people with 2 foldaway benches

Equipment: Entry on driver's side, platform and ladder, lap belts, lighting, heating, fresh air inlet, folding side windows, hinged roof window, telephone connection to the driver, rear-camera and ROPS-certified.

You'll also find attachments online with detailed descriptions:





# PistenBully track setters

## Optimum tracks for skaters and cross-country skiers

The PistenBully 100 SCR track setters have been consistently designed to meet the high demands of skaters and cross-country skiers. Whether for the competition or leisure sector – the result is a perfectly prepared track. The choice of track setters gives ski resort operators a great deal of flexibility when it comes to differing conditions. All track setters are highly precise and require little maintenance.

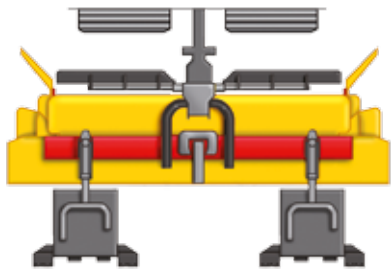

2-way track setter  
2-way track setter with  
lateral adjustment

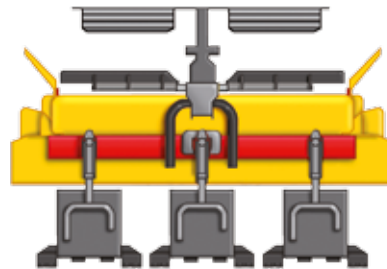

3-way track setter

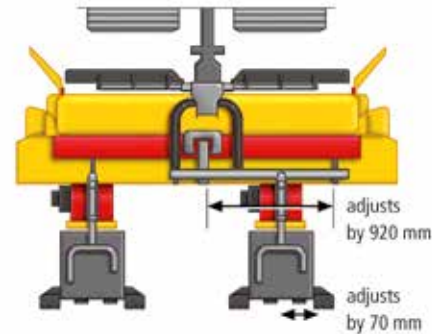

VarioTrackDesigner Classic

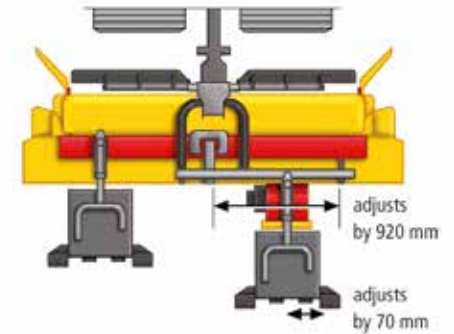

VarioTrackDesigner  
Competition



# Technical data

## for the PistenBully 100 SCR

18

### Engine

Type	Mercedes Benz OM 924 LA
No. of cylinders	4
Displacement	4.80 l / 4,800 ccm
Power output (ECE)	150 kW / 204 hp
Exhaust emissions standard	Tier 4i
Max. torque	800 Nm / 1,200 – 1,600 rpm
Tank capacity	150 l
Additional tank	–
Tank capacity AdBlue®	25 l
Fuel consumption	from 8.5 l/h
Drive pump	71 ccm
Traction drive	63 ccm
Tiller drive	56 ccm

### Driving characteristics

Speed	0 – 23 km/h, continuously variable
Turning radius	on-the-spot

### Electrics

Low-voltage system	24 V
Alternator	28 V / 100 A
Batteries	2 x 12 V / 100 Ah
Cold start rating	680 A

### Lightning

Front	4 halogen front lights, 2 LED working lights
Rear	2 LED working lights

### Cabin

ROPS certificat	yes
Driver's seat	adjustable, air-sprung
Operating elements	indicating instruments, switches
Glazing	Front and rear windows heated, side windows partial heated
Rear mirrors	heated
Wipers	cooling-water heated

### Options

hydraulically foldable sideflaps
brush guard
additional heating
front high pressure connection
solid tyres

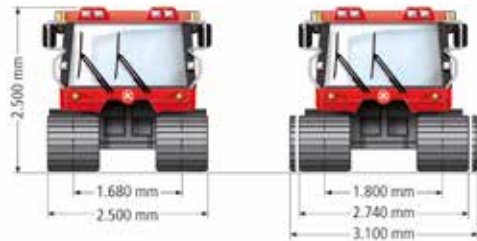

### Weights

Tare weight	with combined tracks / steel tracks	4,440 kg / 4,520 kg / 4,650 kg
	with X-Track chain	4,680 kg / 4,750 kg
Gross weight limit		6,200 kg
Payload on platform		1,500 kg

### Dimensions

Width	without tracks	1,831 mm / 1,951 mm
	over combined tracks / steel tracks	2,500 mm / 2,740 mm / 3,100 mm
	over X-Track chain	2,480 mm / 2,830 mm
	over snow tiller	3,100 mm / 3,400 mm / 3,700 mm
Blade	width open	3,320 mm / 3,820 mm
	width wide	2,720 mm / 3,220 mm
Height	above everything	800 mm
	when driver's cabin tilted	2,500 mm / 3,020 mm
Ground clearance		320 mm
Length	with blade, tiller and track-setter	8,893 mm
Load area	Length	1,620 mm
	Width	1,920 mm
Suggested garage dimensions	Length	8,000 mm
	Width	4,900 mm
	Height	3,200 mm





# PistenBully Service

365 days a year, 24 hours a day:  
our global network is always there  
for you.

## Local service

We know what the breakdown of a snow groomer means to a ski resort. That's why Kässbohrer Geländefahrzeug AG has been investing for decades in a sophisticated, fast-response and globally available service network, which guarantees the availability of service engineers and original spare parts within 24 hours. We now have over 130 service stations and agencies around the world. Because smooth, cost-effective operations are the top priority.

## Advice and training

PistenBully is your partner when it comes to economical use of materials and resources for your fleet. We offer a comprehensive concept of advice and training that will help you to produce the perfect slopes. Technician training ensures your independence and also enables you to perform repairs quickly right in the ski resort.

## Exchange experiences

We share your passion. And we continually exchange experiences with ski resort operators, slope managers and drivers to make sure we're aware of your needs and wishes and to incorporate these in the development of our PistenBully.

You'll find more information on our service concept at:  
[www.pistenbully.com/service](http://www.pistenbully.com/service)

Service partner  
contact list online:



# **PistenBully. For the snow of tomorrow.** Quality, reliability and innovation for over 40 years.

You only get better than “good” with genuine passion and a strong team. A passion for engines, machines and technology is inextricably linked to the Kässbohrer business. Our success is essentially based on these foundations: good ideas that lead to new solutions and a skilled and dedicated team. Our corporate culture encourages a positive innovative climate and enables us to expand our market leadership with fascinating products of the highest quality and reliability.







### **Obligation of quality**

We know the tough conditions in which our vehicles work and the challenges our customers face to work economically. We are convinced that the reliability and quality of our vehicles is the most important added value we can offer our customers.

### **Responsibility for people and the environment**

We see ourselves as a company that takes a responsible approach to its resources, its environment and its relationships with customers, staff and suppliers. Appreciation of people and nature is a valuable asset to us, and this guides our business.



*PistenBully*<sup>®</sup>

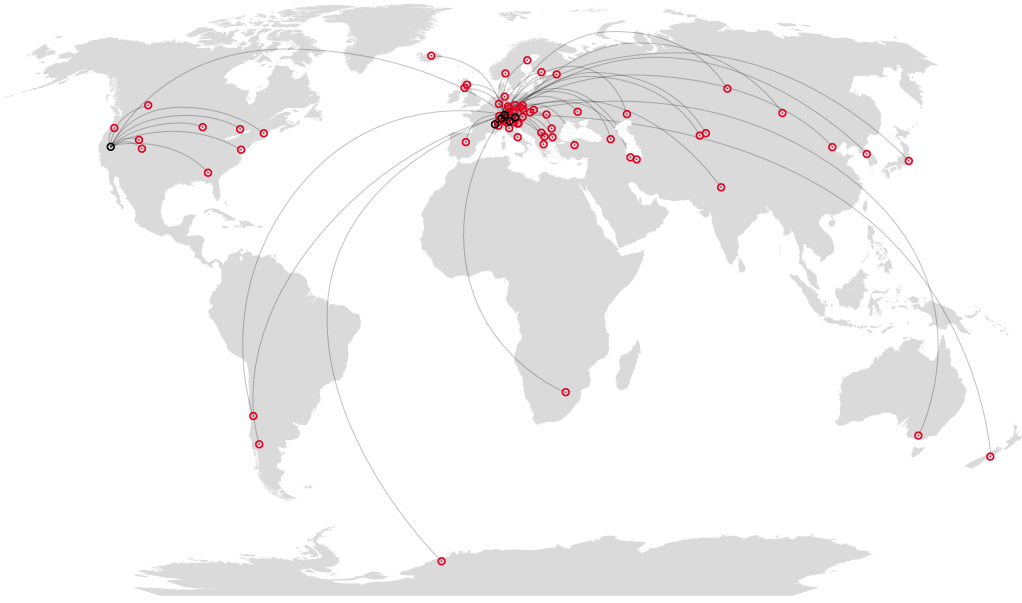

## The global PistenBully Service network

**Kässbohrer Geländefahrzeug AG**  
Kässbohrerstraße 11  
88471 Laupheim  
Telephone +49 (0)7392 900-0  
Telefax +49 (0)7392 900-445  
info@pistenbully.com  
www.pistenbully.com

**Austrian branch**  
Kässbohrer Geländefahrzeug AG  
Gewerbestraße 173  
5431 Kuchl  
Telephone +43 (0)6244 400-10  
Telefax +43 (0)6244 400-111  
office@pistenbully.at  
www.pistenbully.at

**Swiss branch**  
Kässbohrer Geländefahrzeug AG  
Bruneggerstraße 45  
5103 Möriken  
Telephone +41 (0)62 88770-50  
Telefax +41 (0)62 88770-51  
info@pistenbully.ch  
www.pistenbully.ch

**Italian branch**  
Kässbohrer Geländefahrzeug AG  
Via Galileo Galilei, 32  
39100 Bolzano  
Telephone +39 0471 93-3027  
Telefax +39 0471 93-2975  
info@pistenbully.it  
www.pistenbully.it

**French subsidiary**  
Kässbohrer E.S.E.  
455 Route de Marais  
ZAC Porte de Tarentaise  
73790 Tours-en-Savoie  
Telephone +33 (0)479 1046-10  
Telefax +33 (0)479 1046-40  
info@pistenbully.fr  
www.pistenbully.fr

**American subsidiary**  
Kässbohrer All Terrain Vehicles Inc.  
750 A South Rock Boulevard, Reno  
Nevada 89502  
Telephone +1 (0)775 857-5000  
Telefax +1 (0)775 857-5010  
contact@katvpb.com  
www.pistenbullyusa.com

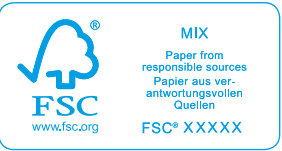

About the details in this catalogue: Changes may have been made to the product after the time of this brochure going to press. The images also contain accessories and special equipment that are not supplied as standard. Slight variations in colour may occur as a result of the printing process. Any statements regarding the statutory, legal and tax regulations and their effects are only valid for the Federal Republic of Germany. For the definitive latest version, please ask your contact at Kässbohrer Geländefahrzeug AG. Printed in Germany on chlorine-free bleached paper.

**PistenBully**  
PistenBully is a registered trademark of Kässbohrer Geländefahrzeug AG.



This company is ISO 14001 and ISO 9001 certified.