

PistenBully[®]

600 Polar SCR

PistenBully 600 Polar SCR

The premium vehicle for maximum ground coverage



PistenBully[®]

Quality Made in Germany

A PistenBully is and remains something special. It encompasses new ideas, technologies and improvements that make it an efficient, safe and user-friendly partner on the slopes. You can rely on the quality of our products made in Germany. And on the fact that sustainability and a responsible approach to people, the environment and resources are an integral part of our philosophy. We use this philosophy to manufacture vehicles that have a concentrated charge of passion and innovation.

As a result, a PistenBully doesn't just do its job. It impresses! That is and remains our standard.



Jens Rottmair
Chief Executive Officer



Michael Kuhn
Head of Development

Jens Rottmair
Chief Executive Officer



2

**FACE THE
CHALLENGE!**





PistenBully 600 Polar SCR

The powerhouse for maximum ground coverage

NEW 100 % performance on any terrain

The PistenBully 600 Polar SCR is equipped with full thrust thanks to an engine with more torque and more powerful hydraulics. Its outstanding steering and drive capabilities resulting from the completely overhauled drive train certainly get your attention. The large tank capacity allows you to cover a lot more ground for snow grooming. Everything for the perfect slope.

NEW More stability. More control.

The PistenBully 600 Polar SCR has a new generation of hydraulic pumps and optimised front hydraulics. Furthermore, we continually strive to improve our vehicles in every detail. This SCR is the best we've ever made.

NEW More efficient working

The requirements of modern snow and fleet management are becoming ever more complex. We have reacted to this. The new PistenBully 600 Polar SCR can be diagnosed remotely and offers the Com-Box operating data evaluation as standard. Optional maintenance agreements complement the service package. In addition, the PistenBully 600 Polar SCR is also available with SNOWsat, an integrated system for real-time guidance, which offers enormous advantages and saving potentials for fleet and snow management, as well as snow production.

NEW Environmentally-friendly motorisation

Thanks to the introduction of the SCR technology, the PistenBully 600 Polar SCR produces 90 % fewer emissions. The reduction in nitrogen emissions is effected in a downstream SCR catalytic converter. The vehicle complies with the Tier 4i exhaust emission regulations. A genuine quality product is not only beautiful but also impresses from a practical perspective. You'll find more information on the engine on page 11.

NEW High driving comfort

A satisfied driver does the best job. We place a lot of value on getting the workstation right. PistenBully pilots now sit in a much quieter space thanks to reduced noise. They retain a clear view of everything via the user-friendly 10.4" touchscreen even when the pressure is on. And many other details like the steering wheel, the ergonomic joystick, the heated windows and the air-sprung driver's seat make the driver's working day that little bit easier.



6

All-Way-Blade

Best thrust performance and power transmission on the market

⦿ Maximum stability and thrust performance

The forces are evenly distributed across the whole vehicle frame during pushing work. This has a positive effect, resulting in a stable drive and outstanding thrust performance.

⦿ High flexibility and ideal roll behaviour

The large All-Way-Blade ensures the highest flexibility. The optimised blade control also helps the driver to achieve precise and stress-free working. The special roll crown on the blade and the extremely well-balanced vehicle geometry as a whole create the best roll characteristics in the snow. For the perfect job.



AlpineFlexTiller

Perfect snow quality even in extreme conditions

⦿ Perfect snow quality

The AlpineFlexTiller even impresses in the toughest conditions with its outstanding performance. The tiller shafts prepare the snow and ensure top-class slope quality. The finished surface has an even cord structure and meets the highest technical standards.

⦿ Optimum adaptation in any situation

Well-thought-out modifications to the tiller guarantee outstanding snow grooming. All setting options can be stored and recalled at any time using the memory function. This means you can react individually and as quickly as possible to changing snow conditions.



4.5-t winch Extra hold and increased safety on the mountain

Whether in use on steep slopes or to shift large volumes of snow: The 4.5-t winch is the perfect complement to the PistenBully 600 Polar SCR for big challenges on the mountain.

The tailor-made winch attachment system with 5 fixing points facilitates quick and easy fitting and removal.

⊕ Maximum load capacity and service life

4.5 tonnes of tensile force, 1,050 metres of rope length, extremely robust winch block, stable slewing ring with hydraulic drive and brakes for secure positioning of the hydraulic, freely rotating driving drum winch – these are some attributes of the 4.5-t winch.

The active winch control that comes as standard also provides optimum steering capability of the machine in difficult snow conditions. Selected steering parameters can be modified to accommodate the snow and slope conditions.

The low-wear winch system and the high durability of the gear wheels and shaft bearings ensure long and safe usage with a low maintenance requirement.

⊕ High safety guaranteed

- Sophisticated control system for optimum steering behaviour
- Large winch hydraulic pump
- Continuously variable rope pull control of 0 – 4,500 kp
- Individual tensile force setting
- Automatic winch winder control, malfunction alerts
- Automatic rope monitoring for early detection of wire and strand breakages
- emergency stop on the steering column
- Alarm signal when winch arm tilted
- Permanent display of remaining rope length
- Specific settings can be adjusted via the continuously variable potentiometer with raster function
- Perfect visibility thanks to newly designed screen wash system



Cockpit

A workstation with well-thought-out ergonomics and visibility

The cockpit of a PistenBully offers comfort, visibility and concentration on the essentials. All instruments and functions are consistently tailored to the needs of the driver and efficient working. For us the ergonomic design of the controls was just as important as the array of top-class technical details. Get in and feel good!

⊕ Improved ergonomics

- Air-sprung, ergonomic driver's seat
- Universal, ergonomic joystick for all PistenBully 600
- Clearly arranged display of all information
- 10.4" touchscreen with greater visibility, higher resolution and brighter display
- Optimised user interface thanks to simple user guidance

⊕ More information

- On-board diagnosis
- Com-Box (telemetry and service communication)

⊕ More comfort, more function

- Heated cab with optimised ventilation system for a pleasant working environment
- Large, heated windows for the best all-round visibility
- Up to 6 dB lower noise level
- Recognisable due to self-explanatory colour coding of functions
- Anti-slip and breathable seat covers
- New additional foldaway seat
- Screen wash system for perfect visibility (on winch vehicles)

⊕ Safety

- ROPS-certified cab (15-tonne roof load)
- Break-proof windscreen



Continuously adjustable – vertically and horizontally – semi-circular steering wheel with multi-function display.



All functions are easy to select via the touchscreen or the terminal control centre.



The PistenBully Joystick – all important functions at your fingertips and, thus, quick to access.

Online:
virtual
cockpit



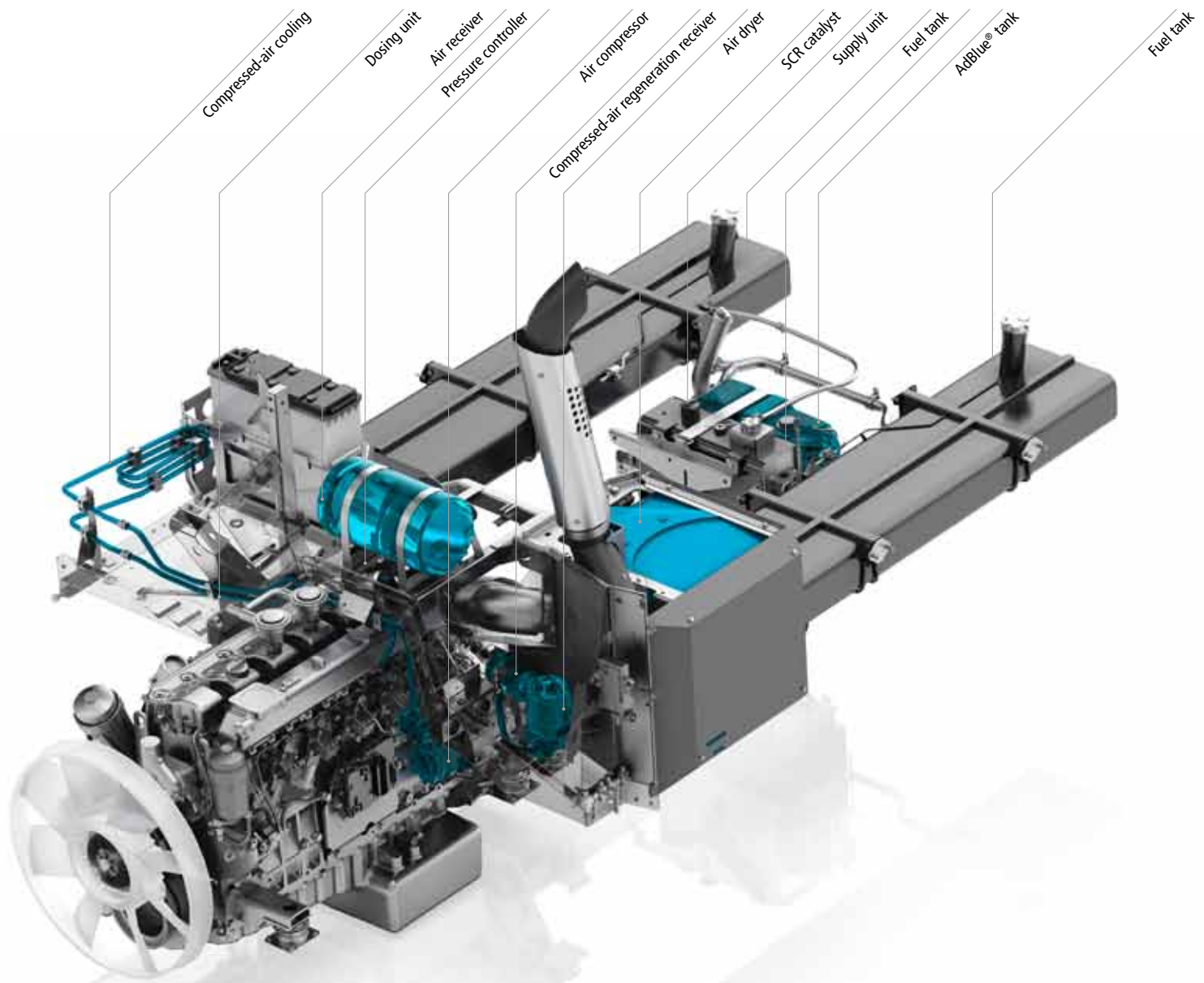

600 Polar SCR engine

A powerful engine for cost-effective peak performance with low emissions

More power and torque, less consumption and 90 % fewer emissions!

With the new engine in the 600 Polar SCR we have achieved several goals simultaneously: a major boost in performance thanks to the improved Mercedes engine, greater power development thanks to a new power train, higher torque at lower engine speeds, less consumption and not least the up to 90 % reduction in CO₂ emissions.

SCR – Selective Catalytic Reduction

The SCR technology primarily reduces the nitrogen oxide (NO_x) in the exhaust gases. However, this largely suppresses unwanted side reactions (e.g. the oxidation of sulphur oxide into sulphur trioxide). This occurs because of the "AdBlue®", an ammonia solution in a separate tank, which is mixed with the exhaust gases. The chemical reaction converts the ammonia and nitrogen oxide into harmless nitrogen and water. The emission of fine dust particles is also substantially reduced by this process.

Compliant with the new Tier 4i exhaust regulations.

The Mercedes-Benz OM 460 LA engine with SCR technology reduces the emission of fuel gases – particularly nitrogen oxide – and complies with the Tier 4i exhaust emission regulations that have been in place since 2011.

Technical data

Type	Mercedes-Benz OM 460 LA
Cylinders	6
Cubic capacity	12.8 l / 12,800 ccm
Power output (ECE)	375 kW (510 hp)
Max. torque	2,200 Nm at 1,300 rpm
Fuel consumption	from 20 l/h
Tank capacity diesel	275 l
Tank capacity AdBlue®	40 l
Emission standard	Tier 4i

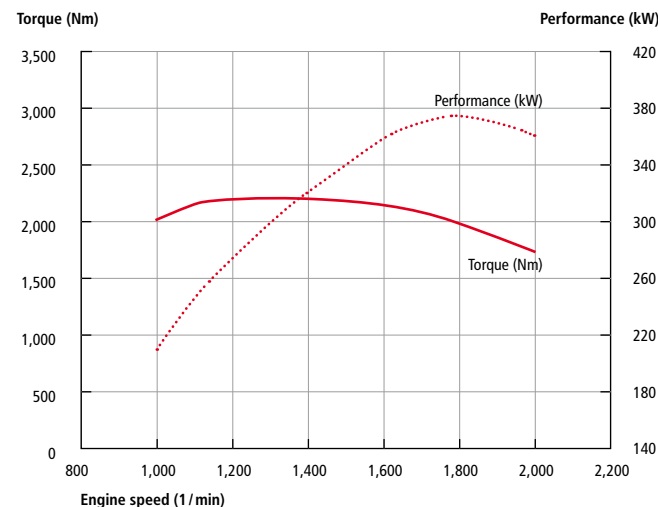











MOTTOLINO
FUN MOUNTAIN



Special model: PistenBully 600 Polar Park SCR

At home in the best fun parks in the world

In 2000, Kässbohrer Geländefahrzeug AG was the first manufacturer to bring a fun park vehicle to the market. To this day, the ParkBully remains the vehicle of choice worldwide when it comes to creating fun parks.

🔗 Flexible and agile

The outstanding kinematics and the coupled hydraulic system make the ParkBully extremely agile with its front and rear attachments. The front and rear attachments can be operated at the same time with a 134° range at the front and a massive 180° at the rear. Perfect for shaping and reshaping kickers, ramps, jumps and pipes.

🔗 For creative head shapers

The rear equipment rack and PSX control make the ParkFlexTiller's range of movement even greater. The ParkBully reaches high up and deep below with its tiller. This results in completely new possibilities: lifting snow overhead, creating precise radii or freely designing shapes. And in addition to the many creative possibilities in the fun park, the ParkBully is of course also ideal for grooming the slopes.

🔗 Perfect for competitions

The park design must continually be altered to ensure the lasting fascination of events. With the ParkBlade from PistenBully moving rails and fun boxes or transporting other objects becomes a one-man job. You'll find this and the other attachments for the ParkBully on page 20.



Extreme agility of the front and rear attachments for perfect shaping and reshaping



The maximum flexibility of the All-Way-Blade facilitates precise shaping of particular designs.



Standard equipment:
With the ParkBlade transporting rails, fun boxes or other park accessories becomes a one-man job.



Standard equipment on the PistenBully 600 Polar SCR

On-board diagnosis

The most important data at a glance immediately and effortlessly



Drivers can access the on-board diagnosis directly from the touchscreen. All functions can be centrally controlled with the fast PSX main computer. Thus, drivers can quickly and effectively access, monitor and evaluate figures on performance and energy management, the engine, the hydraulics and the drive and tiller pumps.

The 10.4" touchscreen offers an improved overview, higher resolution and a bright, illuminated display, which provides optimum contrast day or night.

Magnum sprocket

Premium drive wheel



The Magnum sprocket facilitates optimum power transfer to the tracks. It is extremely high-quality, robust and low-wear over a much longer operating time.

Xenon lights

Optimum illumination of the working areas



The PistenBully lighting concept is perfectly tailored to the working conditions: an extensive xenon lighting package with powerful headlights with low and full beam ensures perfect visibility. Rear and working lights, as well as tree line and sidefinder lights, provide optimum illumination of working areas ahead and behind, the tracks and the areas to the sides.

Optional equipment for the PistenBully 600 Polar SCR

SNOWsat
Professional fleet and
snow management



SNOWsat is a integrated system for guidance, monitoring and coordination of the PistenBully fleet based on GPS and inertial technology. Numerous functions support the central control room and the drivers thanks to efficient snow management. SNOWsat supplies valuable data on snow depth, enabling targeted production of artificial snow and snow grooming and, thus, saves on working time, water and energy.

Technical package
High-pressure connection for
hydraulic front attachments



The PistenBully can be supplemented with other hydraulically operated attachments, such as the front-snow blower or PipeMagician, using an additional high-pressure connection on the front of the vehicle.

Solid tyres
for greater
durability



Solid tyres, which last far longer, are available as an alternative to pneumatic running wheels. These are already installed on the winch vehicles.

Original attachments

100 percent PistenBully quality

PistenBully original attachments don't have an outstanding reputation for nothing. You can rely on the fact that you're getting Made in Germany quality and the usual customer-oriented service.

Naturally, we have combined attachments parts and vehicle components in the best possible way so that everything works perfectly. And last but not least: we know the business and our products and are happy to support and advise you.

Front attachments



PipeMagician

The ideal tool for preparation of half and quarter pipes for competitions. The advantage: they can also be prepared without a winch. With the PipeMagician you can work going uphill and downhill. It can also be stored in a garage once the work is done.



SnowCutter

The SnowCutter is a special tool for breaking up particularly icy sections of snow. This drastically improves the finished quality in conjunction with the AlpineFlexTiller.



Snow bucket

Ideal for shifting snow to the edges of the slopes or from snow depots to remote slope areas. So you can turn poor areas back into perfect slopes. The snow bucket can also be used to transport materials.



Snow gun bracket

The snow gun bracket is a specially developed fixing on the blade for simple and safe transport of snow guns during the season or for removal and storage in summer.



Front-snow blower

Front-snow blower specially developed for the PistenBully for clearing car parks, roads and open areas. Also suitable for moving snow on the slopes.



Blade Loader

Attachment for snow transportation on the slopes or around lifts. Can also be used to replenish remote areas or for shifting and clearing work.



Transport box

The XXL box for transporting materials in the ski resort. It holds up to three Euro pallets and can be stacked for practical storage.

Superstructures



Cab 5 pers. / 700 kg
Cab for moving up to 5 people with foldaway bench.



Cab 10 pers. / 750 kg
Cab for moving up to 10 people with 2 foldaway benches



Cab 15 pers. / 1,600 kg
Cab for moving up to 15 people with 2 foldaway benches and 2 fixed benches.

Equipment: Entry on driver's side, platform and ladder, lap belts, lighting, heating, fresh air inlet, folding side windows, hinged roof window, telephone connection to the driver, rear-camera and ROPS-certified.



Aluminium ski box

Ideal for secure transport of up to 20 pairs of skis or snowboards. Alternatively, you could also store a rescue sledge here. Very easy to fit to the PistenBully.

Rear attachments



4-way track setter

Professional track setter for preparation of 4 cross-country tracks at a time, such as are required for mass-start competitions.



Technical data

PistenBully 600 Polar SCR / 600 W Polar SCR

Engine	600 Polar SCR	600 W Polar SCR
Type	Mercedes Benz OM 460 LA	
No. of cylinders	6	
Displacement	12.82 l / 12,820 ccm	
Power output (ECE)	375 kW / 510 hp	
Exhaust emissions standard	Tier 4i	
Max. torque	2,200 Nm at 1,300 rpm	
Tank capacity	275 l	
Additional tank	–	
Tank capacity AdBlue®	40 l	
Fuel consumption	from 20 l/h	
Drive pump	175 ccm	
Traction drive	125 ccm	
Tiller drive	105 ccm	

Driving characteristics	600 Polar SCR	600 W Polar SCR
Speed	0 – 23 km/h, continuously variable	0 – 20 km/h, continuously variable
Speed with winch in action	0 – 17 km/h	
Gradeability	up to 100%	
Turning radius	on-the-spot	

Electrics	600 Polar SCR	600 W Polar SCR
Low-voltage system	24 V	
Alternator	24 V / 140 A	
Batteries	2 x 12 V / 135 Ah	
Cold start rating	900 A	

Lighting	600 Polar SCR	600 W Polar SCR
Front	4 xenon front-headlights	
Rear	2 xenon rear-headlights	
Lateral	2 TreeLine lights	
Search headlight	Twin searchlights	
Additional headlight	–	on winch boom

Cabin	600 Polar SCR	600 W Polar SCR
ROPS certificat	yes	
Driver's seat	adjustable, air-sprung, heated	
Operating elements	10.4" touchscreen	
Glazing	Front, rear and side windows heated	
Rear mirrors	heated	
Wipers	cooling- water heated	Windshield washer system front / rear

Options	600 Polar SCR	600 W Polar SCR
hydraulically foldable sideflaps	optional	
front high pressure connection	optional	
solid tyres	optional	series
hydraulic oil pre-heating	optional	
trailer hitch	optional	
cableway emergency operation	optional	
rear camera	optional	series
harness belt	optional	series

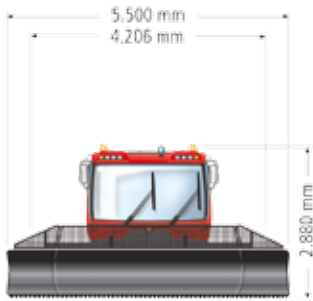

Winch superstructure

600 W Polar SCR

Rope pull	continuously variable	45 kN / 4,590 kp
Rope diameter		11 mm
Rope length		1,050 m
Usable rope length		1,000 m
Rope breaking strain		130 kN / 13,256 kp
Drive rating	at 40 kN pull	110 kW / 150 hp
Weight (winch, rope and superstructure)		2,185 kg

Dimensions

600 Polar SCR / 600 W Polar SCR

Width	without tracks	2,500 mm
	over combined tracks / steel tracks	4,206 mm
	over X-Track chain	3,100 mm
	over tiller with intermediate flaps	5,500 mm
	over tiller and foldable sideflaps	6,050 mm
Blade	width open	5,510 mm
	width wide	4,600 mm
	Height	1,180 mm
Height	above everything	2,880 mm
	above winch ready for operation	3,280 mm
	when driver's cabin tilted	3,360 mm
Ground clearance		350 mm
Length	with blade and tiller	9,130 mm
Load area	Length	1,890 mm
	Width	1,920 mm
Suggested garage dimensions	Length	11,000 mm
	Width	6,000 mm
	Height	3,500 mm

Weights

600 Polar SCR

600 W Polar SCR

Tare weight	with combined tracks	8,500 kg	10,800 kg
	with steel tracks	9,150 kg	11,450 kg
	with X-Track chain	7,960 kg	10,280 kg
Gross weight limit		12,500 kg	13,500 kg
Payload on platform		1,500 kg	2,500 kg





PistenBully Service

365 days a year, 24 hours a day:
our global network is always there
for you.

Local service

We know what the breakdown of a snow groomer means to a ski resort. That's why Kässbohrer Geländefahrzeug AG has been investing for decades in a sophisticated, fast-response and globally available service network, which guarantees the availability of service engineers and original spare parts within 24 hours. We now have over 130 service stations and agencies around the world. Because smooth, cost-effective operations are the top priority.

Advice and training

PistenBully is your partner when it comes to economical use of materials and resources for your fleet. We offer a comprehensive concept of advice and training that will help you to produce the perfect slopes. Technician training ensures your independence and also enables you to perform repairs quickly right in the ski resort.

Exchange experiences

We share your passion. And we continually exchange experiences with ski resort operators, slope managers and drivers to make sure we're aware of your needs and wishes and to incorporate these in the development of our PistenBully.

You'll find more information on our service concept at:
www.pistenbully.com/service

Service partner
contact list online:



PistenBully. For the snow of tomorrow. Quality, reliability and innovation for over 40 years.

You only get better than “good” with genuine passion and a strong team. A passion for engines, machines and technology is inextricably linked to the Kässbohrer business. Our success is essentially based on these foundations: good ideas that lead to new solutions and a skilled and dedicated team. Our corporate culture encourages a positive innovative climate and enables us to expand our market leadership with fascinating products of the highest quality and reliability.





Obligation of quality

We know the tough conditions in which our vehicles work and the challenges our customers face to work economically. We are convinced that the reliability and quality of our vehicles is the most important added value we can offer our customers.

Responsibility for people and the environment

We see ourselves as a company that takes a responsible approach to its resources, its environment and its relationships with customers, staff and suppliers. Appreciation of people and nature is a valuable asset to us, and this guides our business.



PistenBully[®]

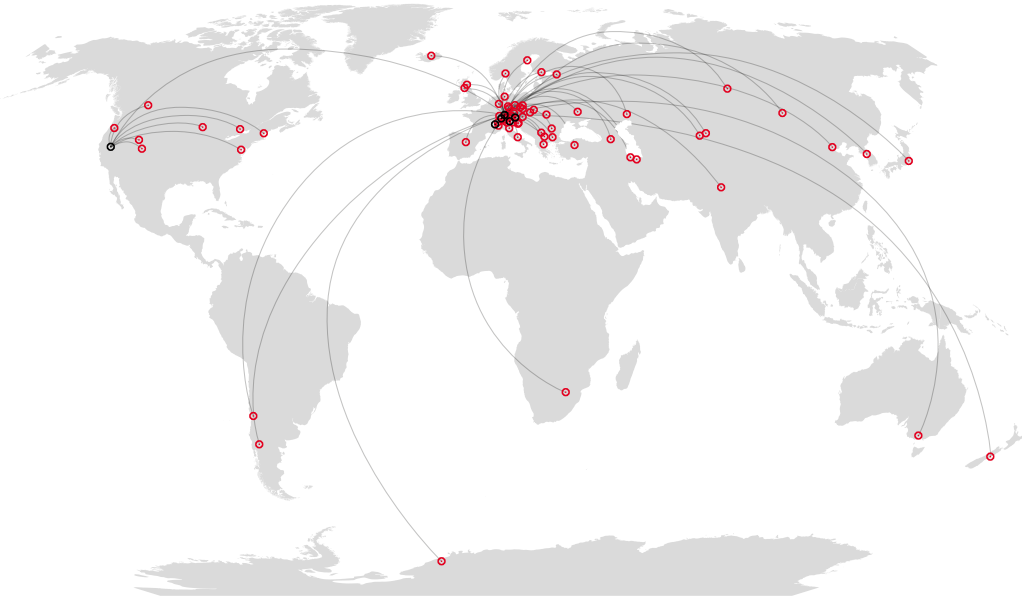

The global PistenBully **Service network**

Kässbohrer Geländefahrzeug AG
Kässbohrerstraße 11
88471 Laupheim
Telephone +49 (0)7392 900-0
Telefax +49 (0)7392 900-445
info@pistenbully.com
www.pistenbully.com

Austrian branch
Kässbohrer Geländefahrzeug AG
Gewerbestraße 173
5431 Kuchl
Telephone +43 (0)6244 400-10
Telefax +43 (0)6244 400-111
office@pistenbully.at
www.pistenbully.at

Swiss branch
Kässbohrer Geländefahrzeug AG
Bruneggerstraße 45
5103 Möriken
Telephone +41 (0)62 88770-50
Telefax +41 (0)62 88770-51
info@pistenbully.ch
www.pistenbully.ch

Italian branch
Kässbohrer Geländefahrzeug AG
Via Galileo Galilei, 32
39100 Bolzano
Telephone +39 0471 93-3027
Telefax +39 0471 93-2975
info@pistenbully.it
www.pistenbully.it

French subsidiary
Kässbohrer E.S.E.
455 Route de Marais
ZAC Porte de Tarentaise
73790 Tours-en-Savoie
Telephone +33 (0)479 1046-10
Telefax +33 (0)479 1046-40
info@pistenbully.fr
www.pistenbully.fr

American subsidiary
Kässbohrer All Terrain Vehicles Inc.
750 A South Rock Boulevard, Reno
Nevada 89502
Telephone +1 (0)775 857-5000
Telefax +1 (0)775 857-5010
contact@katvpb.com
www.pistenbullyusa.com

About the details in this catalogue: Changes may have been made to the product after the time of this brochure going to press. The images also contain accessories and special equipment that are not supplied as standard. Slight variations in colour may occur as a result of the printing process. Any statements regarding the statutory, legal and tax regulations and their effects are only valid for the Federal Republic of Germany. For the definitive latest version, please ask your contact at Kässbohrer Geländefahrzeug AG. Printed in Germany on chlorine-free bleached paper.

PistenBully
PistenBully is a registered trademark of Kässbohrer Geländefahrzeug AG.



This company is ISO 14001 and ISO 9001 certified.