

*PistenBully*<sup>®</sup>

Paana

## PistenBully Paana

The small and manoeuvrable for cross-country tracks and hiking trails



*PistenBully*<sup>®</sup>

# Quality Made in Germany

A PistenBully is and remains something special. It encompasses new ideas, technologies and improvements that make it an efficient, safe and user-friendly partner on the slopes. You can rely on the quality of our products made in Germany. And on the fact that sustainability and a responsible approach to people, the environment and resources are an integral part of our philosophy. We use this philosophy to manufacture vehicles that have a concentrated charge of passion and innovation.

As a result, a PistenBully doesn't just do its job. It impresses! That is and remains our standard.



Jens Rottmair  
Chief Executive Officer



Michael Kuhn  
Head of Development

Jens Rottmair  
Chief Executive Officer

A scenic winter landscape featuring snow-covered mountains, a bridge, and a road. The scene is dominated by white snow, with dark evergreen trees and a wooden bridge visible in the mid-ground. The overall atmosphere is serene and cold.

# **PURSUING THE WINTER DREAM**





# PistenBully Paana

## The small and manoeuvrable for cross-country tracks and hiking trails

### **TOP** Grooming where others cannot go

The Paana is the expert for classic cross-country tracks, skating trails and winter hiking trails – especially when space is tight, the snow covering is thin, or a light surface pressure is required. These situations are when the agile light-weight really comes into its own and gets the job done successfully.

### **TOP** So small, so light, so agile

Thanks to its compact design, low weight and its excellent manoeuvrability, the Paana is so popular for making narrow trails, on tight forest paths or across bridges.

### **TOP** So big and so grown-up

All the tried-and-tested functions of the PistenBully fleet are also available in the compact format of the Paana. Just like its big brothers it combines low operating and maintenance costs with a top price-performance ratio.

### **TOP** So safe, also on the road

Whether fresh snow, ice or road – the Paana drives safely on any terrain. A TÜV certificate confirms its road safety credentials, which means that road-crossing permits can be applied for individually.

### **TOP** Paana: like no other

The little powerhouse is truly unique in its class. In this league there is no real alternative when it comes to professional track grooming. And anyone who's worked with it knows: once with Paana, always with Paana!



## All-Way or 8-Way U-Blade

### Flexible, precise and slimline for the tightest trails and tracks

#### ⦿ For clean working in the snow

The Paana has two well-thought-out blades, which can be used flexibly on any terrain as needed. The All-Way-Blade is the premium tool for challenging work. Thanks to the hydraulically operated side parts, the blade offers a high level of flexibility for diverse terrain and snow situations. This prepares the trail for the following tiller run. The rigid 8-Way U-Blade is the cost-effective alternative, ideal for use on snow-covered winter trails. The two blades have one thing in common: they are robust and reliable and have proven themselves in the field.

## Snow tiller

### Perfect tracks for Nordic sports

#### ⦿ Always the right track thanks to flexible widths

Winter sports terrain is variable – and so are we. That's why the Paana and its associated tillers are available in three different widths for use on the most diverse terrain (see p.13, 15). The high tiller speed ensures the best results, just as you've come to expect from the PistenBully powerhouses. The tiller's hydrostatic drive is backed up by a Rexroth 10VG45 pump, providing maximum flexibility when working in the field. Tiller shaft speed is continuously adjustable as a result. Everything for a perfect track.





## Crawler tracks

### Optimum on thin snow coverings too

#### 🔗 Gentle, but tough

The Paana works very gently and can even groom extremely thin snow coverings lightly and safely. Anyone working on extremely sensitive terrain or on very little snow, can opt for the low-profile crawler tracks with a base height of 62 mm rather than the standard 72 mm, or for the X-Track chain. The open web profiles of the Paana's crawler tracks are made of hardened steel. This guarantees low wear and a long service life.



# Cockpit

## This is how you make working fun

A cockpit with a view: the huge windows and the center seat provide uninterrupted view in all directions. The one-seat driver's cab meets the high safety standards of the ROPS certification. A large sun roof, three-stage heating system and the ergonomic and clearly arranged control elements make the cockpit a pleasant place to work. The air-sprung and heated driver's seat also adds to the comfortable working environment. Highly practical and ideal on long trips: the cruise control button integrated in the steering wheel. It ensures economical runs and even results during grooming.

### ⊕ Improved ergonomics

- Air-sprung, ergonomic driver's seat
- Ergonomically designed joystick
- Clearly arranged display of all information
- Cruise control for consistent speed

### ⊕ More comfort, more function

- Heated cab with large ventilation system for a pleasant working environment
- Large, heated windows for the best all-round visibility
- Non-slip and breathable seat covers

### ⊕ Safety

- ROPS-certified cab



Comfort down to the last detail: the adjustable steering wheel adapts to the driver.



Everything at a glance: the PistenBully Paana's dashboard is clearly arranged and intuitive to use.



All important functions are integrated into the ergonomically designed joystick.



Online:  
virtual  
cockpit

# Paana engine

## A true endurance athlete

### ⊕ Strong drive

It is efficient and always full of power. The Paana packs 115 hp and a powerful Cummins 4-cylinder in-line engine with turbo charger.

With output settings of 86 kW you can rely on the Paana's drive. The turbo charger and air/air intercooling guarantee powerful performance. It has a maximum torque of 488 Nm at 1,500 rpm. Reliable strong power – on any terrain.

### Technical data

Type	Cummins QSB 4.5
Cylinders	4
Displacement	4.5 l / 1.19 gal 4,500 ccm / 274.6 cu.in
Power output (ECE)	86 kW (115 hp)
Max. torque	488 Nm at 1,500 rpm
Fuel consumption	from 10 l/h / 2.64 gal/h
Tank capacity	120 l / 31.7 gal
Exhaust emissions standard	Euro 3A

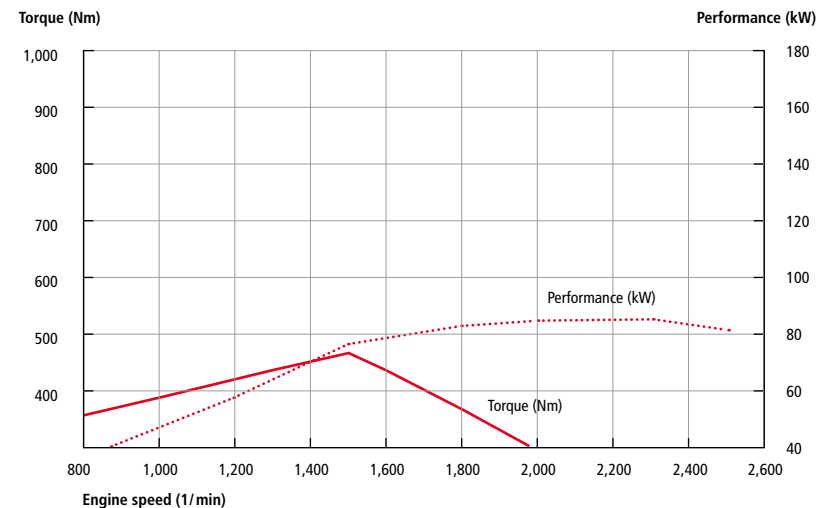

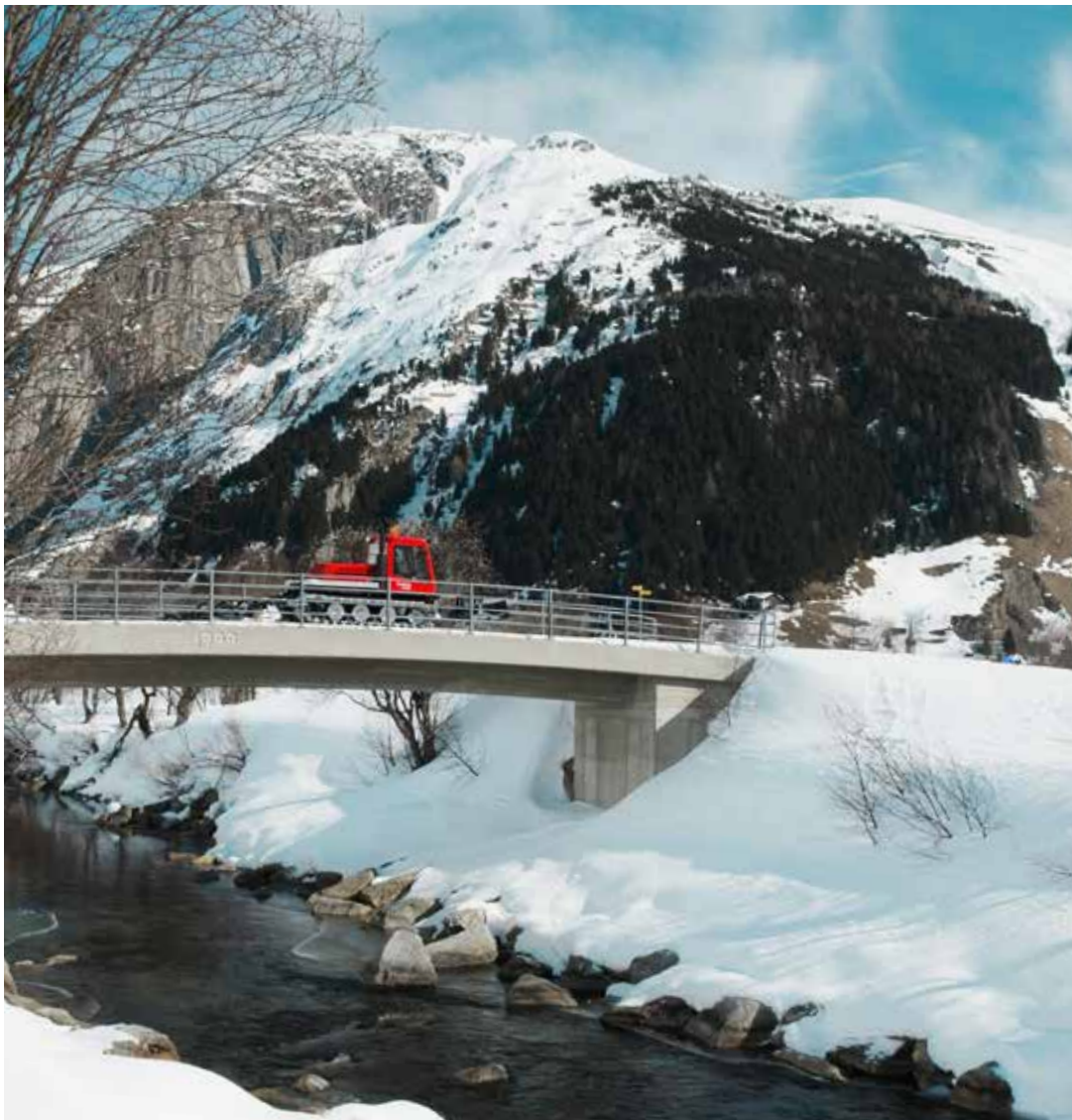



12



2-way track setter Paana

Also available as 2-way track setter VarioTrack-Designer Competition with track-setting tiller before the right-hand track setter, plus track width adjustment and hydraulic adjustment of the right-hand track setter. The left track setter is fixed, with no track-setting tiller or adjustability.

# PistenBully 2-way track setters

## Optimum tracks for skaters and cross-country skiers

The track setters for the Paana are available in three different widths. They effortlessly groom all types of snow: from fresh snow to the hardest packed ice. Thanks to the two-stage tiller system, drivers can now produce cross-country ski trails that meet the high FIS requirements in just a single run.

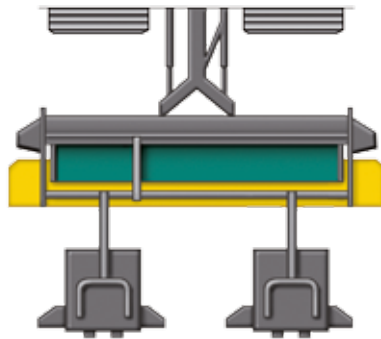

2-way track setter

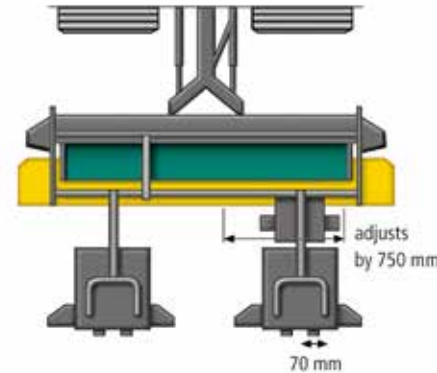

VarioTrackDesigner  
Competition



# Technical data

## PistenBully Paana

### Engine

Type	Cummins QSB 4.5
No. of cylinders	4
Displacement	4.5 l / 1.19 gal 4,500 ccm / 274.6 cu.in
Power output (ECE)	86 kW / 115 hp
Exhaust emissions standard	Euro 3A
Max. torque	488 Nm at 1,500 rpm
Tank capacity	120 l / 31.7 gal
Fuel consumption	from 10 l/h / 2.64 gal/h

### Driving characteristics

Speed, continuously variable	0 – 20 km/h / 0 – 12.5 mph, continuously variable
Turning radius	on-the-spot

### Electrics

Low-voltage system	24 V
Alternator	28 V / 70 A
Batteries	2 x 12 V / 64 Ah

### Cabin

ROPS certificat	yes
Driver's seat	air-sprung center seat
Operating elements	multi-function display
Rear mirrors	heated

### Options

hydraulically foldable sideflaps
Brush guard



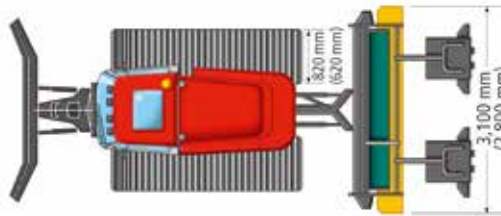
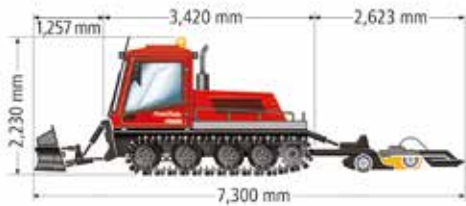

### Weights

Tare weight	with combined tracks	3,000 kg / 6,614 lbs
	steel tracks	3,100 kg / 6,834 lbs
Gross weight limit		3,750 kg / 8,267 lbs
		3,850 kg / 8,488 lbs

### Dimensions

Width	without tracks	1,480 mm / 58.3"
	over combined tracks /	2,100 mm / 87.7"
	steel tracks	2,500 mm / 98.4"
	over tiller	2,200 mm / 86.6"
		2,800 mm / 110.2"
		3,100 mm / 122.1"
All-Way-Blade	over tiller and foldable sideflaps	3,300 mm / 129.9"
		3,900 mm / 153.4"
		4,200 mm / 165.4"
	Width open	2,930 mm / 115.4"
Height	Width wide	2,735 mm / 107.7"
	Height	760 mm / 29.9"
	above everything	2,230 mm / 87.8"
Length	with blade and tiller	6,220 mm / 244.9"
	with blade, tiller and track-setters	7,310 mm / 287.8"
Suggested garage dimensions	Length	8,000 mm / 315"
	Width	4,000 mm / 158"
	Height	3,000 mm / 119"



*John Deere*  
topservice



# PistenBully Service

365 days a year, 24 hours a day:  
our global network is always there  
for you.

## Local service

We know what the breakdown of a snow groomer means to a ski resort. That's why Kässbohrer Geländefahrzeug AG has been investing for decades in a sophisticated, fast-response and globally available service network, which guarantees the availability of service engineers and original spare parts within 24 hours. We now have over 130 service stations and agencies around the world. Because smooth, cost-effective operations are the top priority.

## Advice and training

PistenBully is your partner when it comes to economical use of materials and resources for your fleet. We offer a comprehensive concept of advice and training that will help you to produce the perfect slopes. Technician training ensures your independence and also enables you to perform repairs quickly right in the ski resort.

## Exchange experiences

We share your passion. And we continually exchange experiences with ski resort operators, slope managers and drivers to make sure we're aware of your needs and wishes and to incorporate these in the development of our PistenBully.

You'll find more information on our service concept at:  
[www.pistenbully.com/service](http://www.pistenbully.com/service)

Service partner  
contact list online:



# **PistenBully. For the snow of tomorrow.** Quality, reliability and innovation for over 40 years.

You only get better than “good” with genuine passion and a strong team. A passion for engines, machines and technology is inextricably linked to the Kässbohrer business. Our success is essentially based on these foundations: good ideas that lead to new solutions and a skilled and dedicated team. Our corporate culture encourages a positive innovative climate and enables us to expand our market leadership with fascinating products of the highest quality and reliability.





### **Obligation of quality**

We know the tough conditions in which our vehicles work and the challenges our customers face to work economically. We are convinced that the reliability and quality of our vehicles is the most important added value we can offer our customers.

### **Responsibility for people and the environment**

We see ourselves as a company that takes a responsible approach to its resources, its environment and its relationships with customers, staff and suppliers. Appreciation of people and nature is a valuable asset to us, and this guides our business.



*PistenBully*<sup>®</sup>

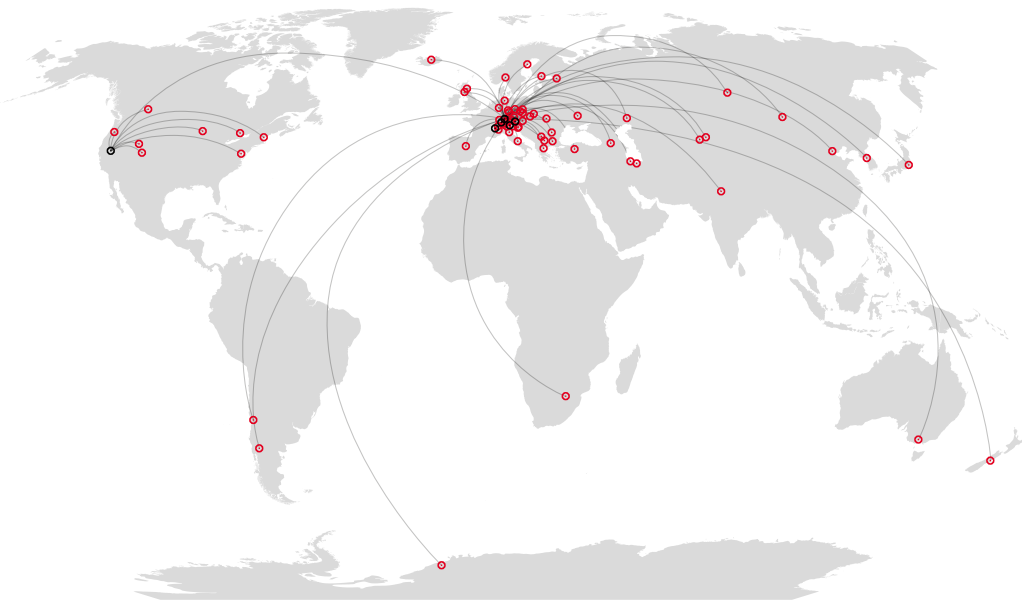

## The global PistenBully **Service network**

### **Kässbohrer Geländefahrzeug AG**

Kässbohrerstraße 11  
88471 Laupheim  
Telephone +49 (0)7392 900-0  
Telefax +49 (0)7392 900-445  
info@pistenbully.com  
www.pistenbully.com

### **Italian branch**

Kässbohrer Geländefahrzeug AG  
Via Galileo Galilei, 32  
39100 Bolzano  
Telephone +39 0471 93-3027  
Telefax +39 0471 93-2975  
info@pistenbully.it  
www.pistenbully.it

### **Austrian branch**

Kässbohrer Geländefahrzeug AG  
Garnei 173  
5431 Kuchl  
Telephone +43 (0)6244 400-10  
Telefax +43 (0)6244 400-111  
office@pistenbully.at  
www.pistenbully.at

### **French subsidiary**

Kässbohrer E.S.E.  
455 Route de Marais  
ZAC Porte de Tarentaise  
73790 Tours-en-Savoie  
Telephone +33 (0)479 1046-10  
Telefax +33 (0)479 1046-40  
info@pistenbully.fr  
www.pistenbully.fr

### **Swiss branch**

Kässbohrer Geländefahrzeug AG  
Bruneggerstraße 45  
5103 Möriken  
Telephone +41 (0)62 88770-50  
Telefax +41 (0)62 88770-51  
info@pistenbully.ch  
www.pistenbully.ch

### **American subsidiary**

Kässbohrer All Terrain Vehicles Inc.  
8850 Double Diamond Parkway  
89521 Reno, Nevada  
Telephone +1 (0)775 857-5000  
Telefax +1 (0)775 857-5010  
contact@pistenbullyusa.com  
www.pistenbullyusa.com

About the details in this catalogue: Changes may have been made to the product after the time of this brochure going to press. The images also contain accessories and special equipment that are not supplied as standard. Slight variations in colour may occur as a result of the printing process. Any statements regarding the statutory, legal and tax regulations and their effects are only valid for the Federal Republic of Germany. For the definitive latest version, please ask your contact at Kässbohrer Geländefahrzeug AG. Printed in Germany on chlorine-free bleached paper.

**PistenBully**

PistenBully is a registered trademark of Kässbohrer Geländefahrzeug AG.



**KÄSSBOHRER GELÄNDEFahrZEUG AG**



This company is ISO 14001 and ISO 9001 certified.