

*PowerBully*<sup>®</sup>

Track Carriers

**PowerBully Track Carriers**  
Strong and rugged for challenging tasks.



*PowerBully*<sup>®</sup>

# Welcome to PowerBully...

We are Kässbohrer Geländefahrzeug AG, a world market leader in tracked vehicle equipment, known around the globe for quality products, engineering, technology and commitment to the customer.

With the recent acquisition of Soft Track Supply, Kässbohrer leverages its 45 years of track vehicle experience in order to continue its growth within the utility markets. We are proud to introduce to this market a new class of heavy payload track carriers, now known as PowerBully.

PowerBully represents a significant investment in engineering, production and quality control that will serve to strengthen our business and grow our markets.

Our mission is to be number one with our customers. We are a German based track vehicle company with 3 manufacturing facilities. When we combine these facilities with our extended sales and service network with 135 partners worldwide, you can be sure that we have the parts, service and technical expertise to be a valuable member of your track vehicle team.

On behalf of the new PowerBully, thank you for your past, present and future business. We are excited to continue our growth in the utility market and look forward to becoming a reliable addition to your lineup.



Jens Rottmair  
Chief Executive Officer











## PowerBully Simply built better.

With payload capacities of up to 35,000 lbs, the rugged PowerBully has the low ground pressure platform you need from a tracked carrier. Our focus on safety, engineering and minimal environmental impact ensures PowerBully is the right tool to get your job done.

PowerBully offers a proven lineup of heavy duty low ground pressure track carriers that offer the best platform for transmission and distribution projects, powerline construction and pipeline maintenance.

Our light footprint ensures you have the right vehicle to access those hard to reach locations, even in the most demanding of weather conditions.

- ⊕ Largest service network
- ⊕ Best in class two year warranty
- ⊕ Direct communication with PowerBully engineering
- ⊕ All PowerBully parts in stock
- ⊕ Overnight shipping
- ⊕ ROPS & FOPS ergonomic cabin options
- ⊕ Reliable, EPA-certified Cummins powerplant
- ⊕ Hydrostatic and mechanical transmission options
- ⊕ Grouser bar options with D Dent, Flat or Urethane
- ⊕ 45 years track vehicle experience



## PowerBully 5T Payloads up to 16,000 lbs

**PowerBully means dependability** and the PowerBully 5T is the track carrier for quick transport to your job site. With the Cummins engine, reinforced chassis and a digger derrick, the versatile PowerBully 5T can make swift work of power pole replacement.

- ⊕ Legal width for ease of transport
- ⊕ Hydrostatic transmission
- ⊕ Low ground pressure
- ⊕ Urethane track options



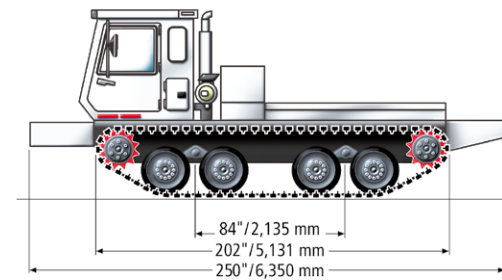
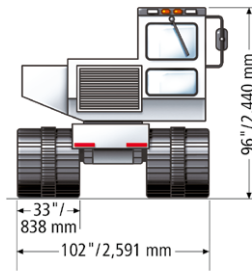

### Engine

Type	Cummins QSB 6.7 turbo diesel
No. of cylinders	6
Displacement	6.7 l / 1.8 gal 6,700 ccm / 408 cu.in
Power output (ECE)	191 kW / 260 hp
Exhaust emissions standard	TIER 3
Max. torque	990 Nm at 1,500 rpm
Tank capacity	190 l / 50 gal
Cooling system	23 l / 6 gal
Hydrostatic tank	378 l / 100 gal

### Driving characteristics

Speed	0 – 8 km/h / 0 – 5 mph	
Fording depth	1,060 mm / 42"	
Turning radius	on-the-spot	
Ground pressure	No penetration	6" penetration / 150 mm
	Standard vehicle	2.4 psi    2.05 psi
	Loaded vehicle	4.77 psi    3.52 psi
Max. grade ability		
	Uphill/downhill	60%    31°
	Side hill	40%    22°

### Electrics

Low-voltage system	12 V
Alternator	130 A
Batteries	2 x 1,100 cca

### Transmission

Pump drive	Durst
Hydrostatic	Sauer Danfoss independent control of each track
Steering control	Dual stick w/low & high range control
Torque hub	Fairfield

### Chassis

Type	Tub; access panels & drain plug
Suspension	Walking beam
Wheels	8 solid rubber, 6.5 x 16

### Tracks

Type	2 belt w/ steel crosslinks
Belting	Rubber, 5 ply
Width	838 mm / 33"
Tensioner	Grease filled cylinder

### Weights

Tare weight* (basic vehicle)	from 8,430 kg / 18,580 lbs
Gross weight limit	15,685 kg / 34,580 lbs
Payload on platform	7,260 kg / 16,000 lbs

\*In acc. with ISO 1176/M6, net weights may vary depending on equipment.

### Dimensions

Overall width	2,591 mm / 102"	
Overall height	2,440 mm / 96"	
Ground clearance	457 mm / 18"	
Overall length standard	6,350 mm / 250"	
Suggested garage dimensions	Length	9,400 mm / 370"
	Width	4,880 mm / 192"
	Height	3,200 mm / 126"

### Options

One person or two person cab
Heavy duty brush guards
Rear pintle hook
Air conditioning
Arctic package
Spotlight-remote control
Winch
Rear view camera
Amber beacon light
Electronic inclinometer
3rd battery
Hi flow hydraulics: for drills, cranes, knuckle booms, man lifts, digger derricks, backhoes
Single stick steering



## PowerBully 10T Payloads up to 25,000 lbs

**PowerBully means flexibility** and the PowerBully 10T is the track carrier platform for your unique application. As a preferred track vehicles for fire fighting, this model can be built to carry a 750 gallon water tank, or reinforced to pull fire plows, all to provide you with an effective and efficient way to fight remote fires.

- ⊕ Customized vehicles for special applications
- ⊕ Specialized firefighting vehicle
- ⊕ Specialized fabrication options
- ⊕ Mechanical drive availability



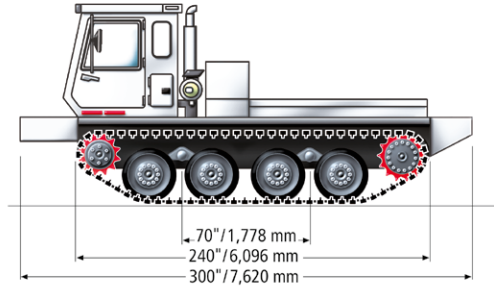
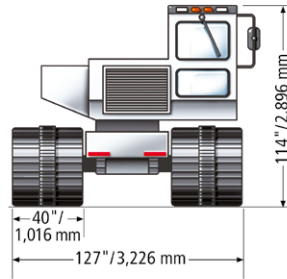

### Engine

Type	Cummins QSB 6.7 turbo diesel
No. of cylinders	6
Displacement	6.7 l / 1.8 gal 6,700 ccm / 408 cu.in
Power output (ECE)	191 kW / 260 hp
Exhaust emissions standard	TIER 3
Max. torque	990 Nm at 1,500 rpm
Tank capacity	300 l / 80 gal
Cooling system	23 l / 6 gal
Hydrostatic tank	435 l / 115 gal

### Driving characteristics

Speed	0 – 10 km/h / 0 – 6.5 mph	
Fording depth	1,060 mm / 42"	
Turning radius	on-the-spot	
Ground pressure	No penetration	6" penetration / 150 mm
	Standard vehicle	2.4 psi    1.75 psi
	Loaded vehicle	4.84 psi    4.16 psi
Max. grade ability		
	Uphill/downhill	60 %    31°
	Side hill	40 %    22°

### Electrics

Low-voltage system	12 V
Alternator	130 A
Batteries	2 x 1,100 cca

### Transmission

Pump drive	Durst
Hydrostatic	Sauer Danfoss independent control of each track
Steering and control	Dual stick w/low & high range
Mechanical transmission	optional

### Chassis

Type	Tub; access panels & drain plug
Suspension	Walking beam
Wheels	8 solid rubber, 6.5 x 16

### Tracks

Type	2 belt w/ steel crosslinks
Belting	Rubber, 6 ply
Width	1,016 mm / 40"
Tensioner	Grease filled cylinder

### Weights

Tare weight* (basic vehicle)	from 9,980 kg / 22,000 lbs
Gross weight limit	19,050 kg / 42,000 lbs
Payload on platform	11,300 kg / 25,000 lbs

\*In acc. with ISO 1176/M6, net weights may vary depending on equipment.

### Dimensions

Overall width	3,226 mm / 127"	
Overall height	2,896 mm / 114"	
Ground clearance	444.5 mm / 17.5"	
Overall length standard	7,620 mm / 300"	
Suggested garage dimensions	Length	10,670 mm / 420"
	Width	5,720 mm / 225"
	Height	3,660 mm / 144"

### Options

One person or two person cab
Heavy duty brush guards
Rear pintle hook
Air conditioning
Arctic package
Spotlight-remote control
Winch
Rear view camera
Amber beacon light
Electronic inclinometer
3rd battery
Hi flow hydraulics: for drills, cranes, knuckle booms, man lifts, digger derricks, backhoes



## PowerBully 15T Payloads up to 35,000 lbs

**PowerBully means power** and the PowerBully 15T is the machine of choice for more challenging industry applications. With a strong reinforced tub frame made from high strength steel, a platform deck that can accommodate most attachments and low ground pressure, the PowerBully 15T model handles almost any task.

- ⊕ Practical and proven
- ⊕ Two year warranty
- ⊕ Various track options
- ⊕ Multiple belt width configurations
- ⊕ Cummins EPA certified engine



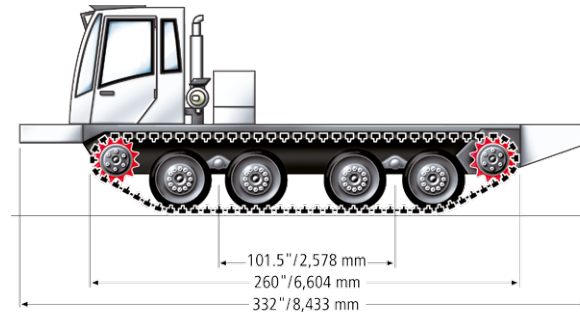
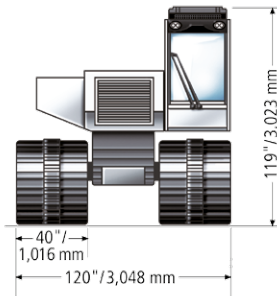

### Engine

Type	Cummins QSB 6.7 turbo diesel
No. of cylinders	6
Displacement	6.7 l / 1.8 gal 6,700 ccm / 408 cu.in
Power output (ECE)	191 kW / 260 hp
Exhaust emissions standard	TIER 3
Max. torque	990 Nm at 1,500 rpm
Tank capacity	300 l / 80 gal
Cooling system	23 l / 6 gal
Hydrostatic tank	435 l / 115 gal

### Driving characteristics

Speed	0 – 10 km/h / 0 – 6.5 mph	
Fording depth	1,320 mm / 52"	
Turning radius	on-the-spot	
Ground pressure	No penetration	6" penetration / 150 mm
	Standard vehicle	2.4 psi    1.75 psi
	Loaded vehicle	4.77 psi    4.16 psi
Max. grade ability		
	Uphill/downhill	60 %    31°
	Side hill	40 %    22°

### Electrics

Low-voltage system	12 V
Alternator	130 A
Batteries	2 x 1,100 cca

### Transmission

Pump drive	Durst
Hydrostatic	Sauer Danfoss independent control of each track
Steering and control	Dual stick w/low & high range
Torque hub	Fairfield

### Chassis

Type	Tub; access panels & drain plug
Suspension	Walking beam
Wheels	8 solid rubber, 9.0 x 20

### Tracks

Type	2 belt w/ steel crosslinks
Belting	Rubber, 6 ply
Width	1,016 mm / 40"
Tensioner	Grease filled cylinder

### Weights

Tare weight* (basic vehicle)	from 11,340 kg / 25,000 lbs
Gross weight limit	27,220 kg / 60,000 lbs
Payload on platform	15,880 kg / 35,000 lbs

\*In acc. with ISO 1176/M6, net weights may vary depending on equipment.

### Dimensions

Overall width	3,048 mm / 120"	
Overall height	3,023 mm / 119"	
Ground clearance	508 mm / 20"	
Overall length standard	8,433 mm / 332"	
Suggested garage dimensions	Length	11,480 mm / 452"
	Width	6,100 mm / 240"
	Height	4,270 mm / 168"

### Options

One person or two person cab
Heavy duty brush guards
Rear pintle hook
Air conditioning
Arctic package
Spotlight-remote control
Winch
Rear view camera
Amber beacon light
Electronic inclinometer
3rd battery
Hi flow hydraulics: for drills, cranes, knuckle booms, man lifts, digger derricks, backhoes

# PowerBully – Flexibility for your application. Power to your industry.

PowerBully offers the perfect mobile base for digger derricks, cranes, man lifts, knuckle booms and backhoes.

PowerBully are perfect tools for the maintenance and construction of pipelines, power and telephone lines, fire control, soil testing and many more.

If you have a specific challenge that requires the mounting and application of specialized equipment, please call our technical support team. We are ready to assist you with your needs.

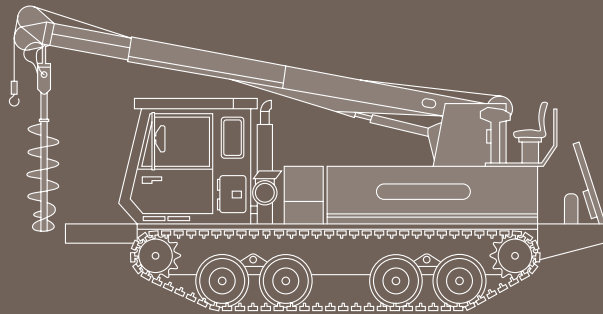

**Digger derrick**

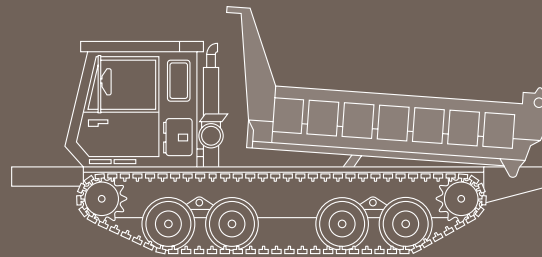

**Dump body**

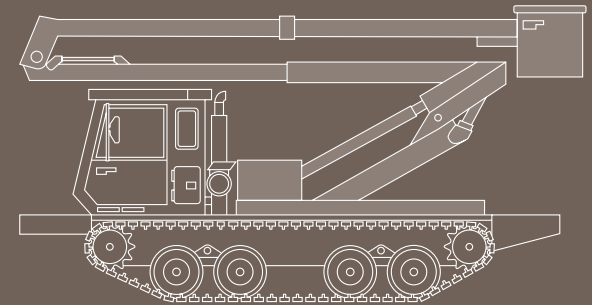

**Man lift**



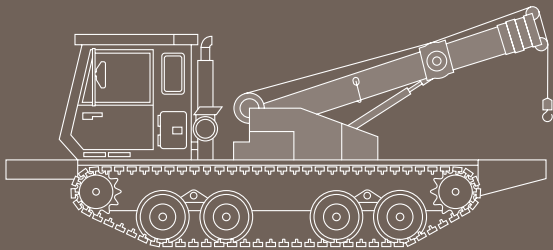

**Aerial crane**

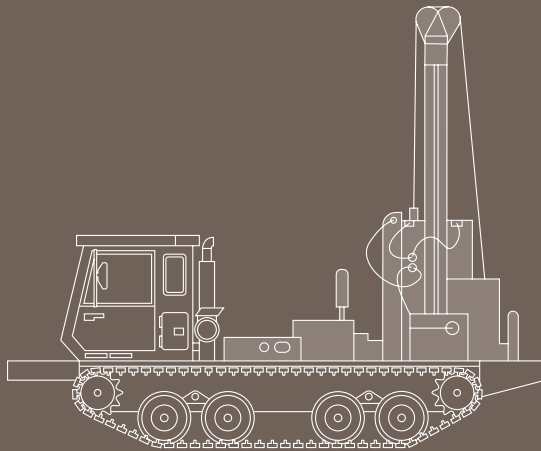

**Vertical drill**

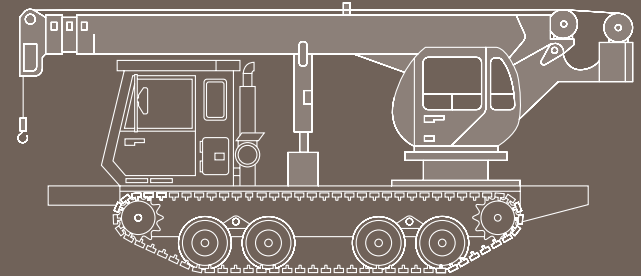

**Telescoping crane**

# PowerBully Service 365 days a year, 24 hours a day.

The name Kässbohrer is known around the world for leading edge quality, customer service and quick response. With industry leading parts inventory availability, and access to overnight shipping, we are here to ensure your equipment is always ready to deploy.

## Welcome to PowerBully

Whatever your project calls for, whatever your application demands, choose PowerBully to be your preferred track carrier partner. We are built to succeed for you.

- ⊕ Complete parts inventory available
- ⊕ 135 factory authorized service locations
- ⊕ PowerBully technicians strategically located across the world
- ⊕ After hours emergency call center

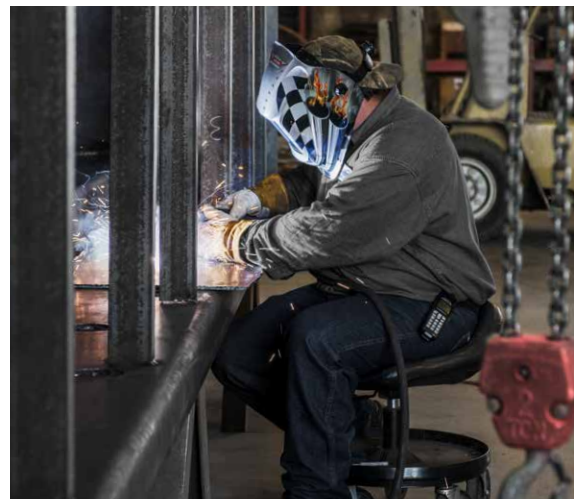
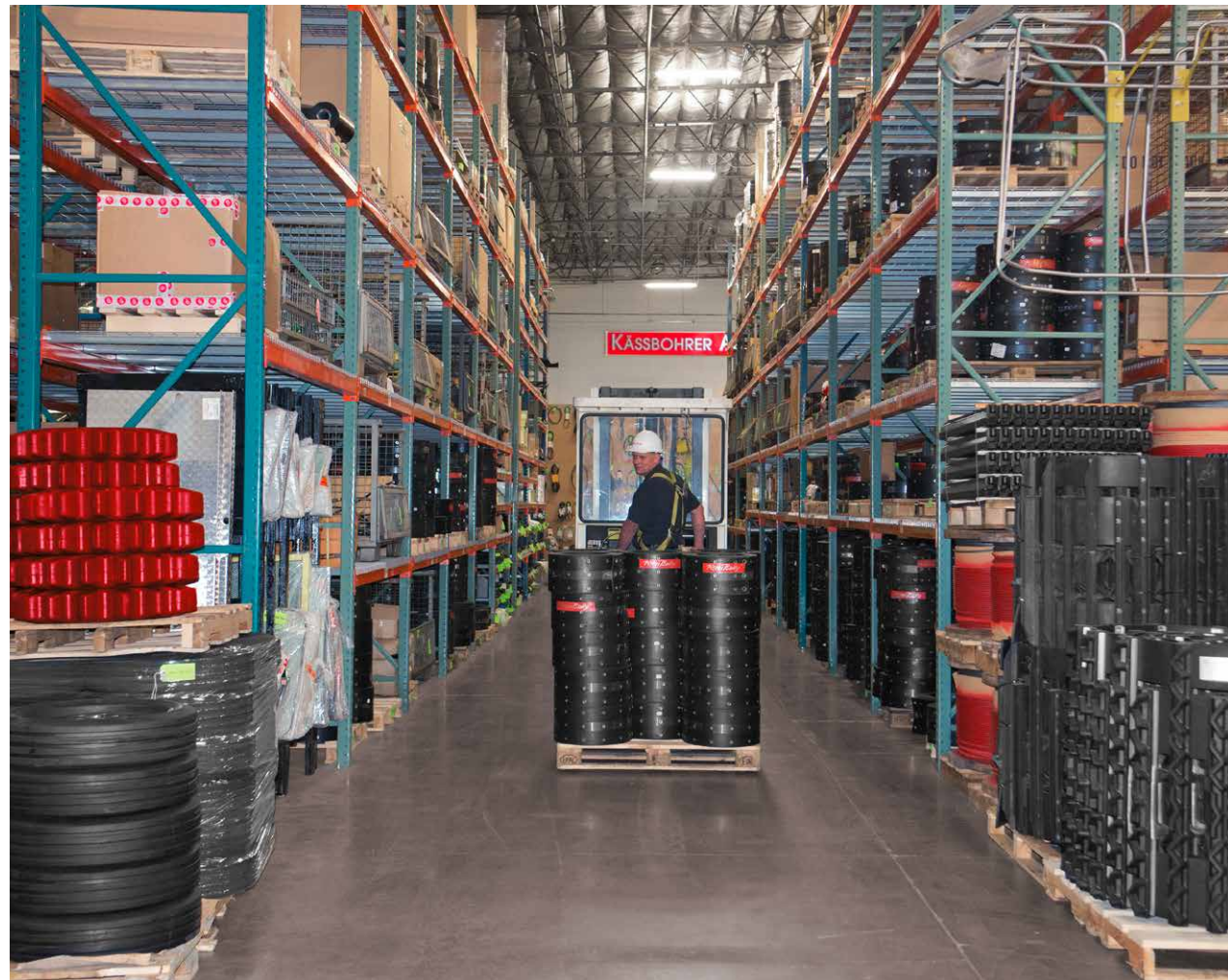





PowerBully®

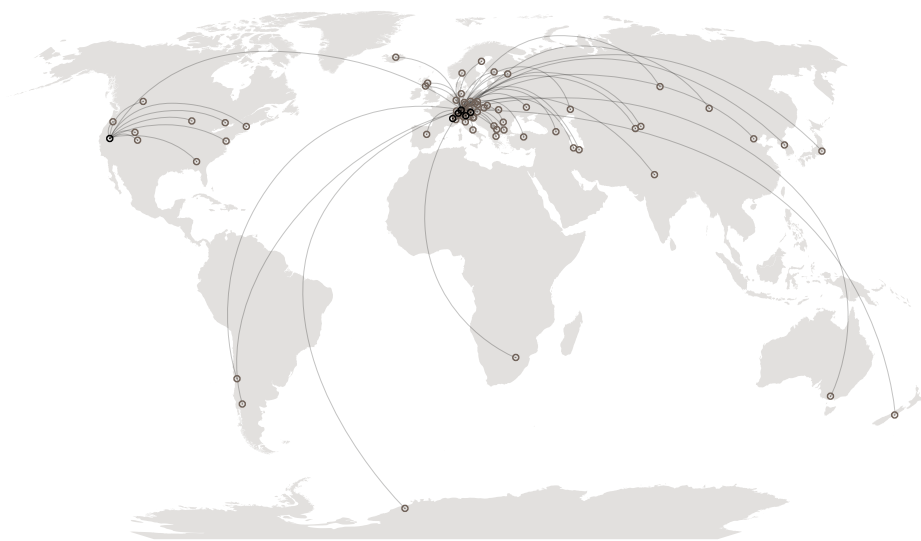

## The global PowerBully network.

### Kässbohrer Geländefahrzeug AG

Kässbohrerstraße 11  
88471 Laupheim  
Telephone +49 (0)7392 900-0  
Telefax +49 (0)7392 900-445  
info@pistenbully.com  
www.pistenbully.com

### Austrian branch

Kässbohrer Geländefahrzeug AG  
Garnei 173  
5431 Kuchl  
Telephone +43 (0)6244 4001-0  
Telefax +43 (0)6244 4001-11  
office@pistenbully.at  
www.pistenbully.at

### Swiss branch

Kässbohrer Geländefahrzeug AG  
Bruneggerstraße 45  
5103 Möriken  
Telephone +41 (0)62 88770-50  
Telefax +41 (0)62 88770-51  
info@pistenbully.ch  
www.pistenbully.ch

### Italian subsidiary

Kässbohrer Italia S.r.l.  
Via Galileo Galilei, 32  
39100 Bolzano  
Telephone +39 0471 93-3027  
Telefax +39 0471 93-2975  
info@pistenbully.it  
www.pistenbully.it

### French subsidiary

Kässbohrer E.S.E.  
455 Route de Marais  
ZAC Porte de Tarentaise  
73790 Tours-en-Savoie  
Telephone +33 (0)479 1046-10  
Telefax +33 (0)479 1046-40  
info@pistenbully.fr  
www.pistenbully.fr

### American subsidiary

Kässbohrer All Terrain Vehicles, Inc.  
8850 Double Diamond Parkway  
89521 Reno, Nevada  
Telephone +1(0) 775 857-5000  
Telefax +1(0) 775 857-5020  
contact@pistenbullyusa.com  
www.pistenbullyusa.com

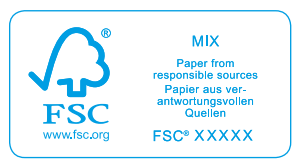

On the details in this catalogue: there may have been product changes after this issue went to print. The images also include accessories and special equipment, which are not supplied as standard. The printing process may cause colour deviations. Statements on compulsory, legal and fiscal regulations and implications are only valid for Germany. Therefore, please ask your contact at Kässbohrer Geländefahrzeug AG for the final status. Printed in Germany.



PowerBully is a registered trademark of Kässbohrer Geländefahrzeug AG.



KÄSSBOHRER GELÄNDEFahrZEUG AG



This company is ISO 14001 and ISO 9001 certified.