

Operating Manual



**Drum winch 4,5 to
PistenBully 600W**

From WKU 5 826 MA B L 011249

EN

www.pistenbully.com

PistenBully®



Kässbohrer Geländefahrzeug AG

Kässbohrerstrasse 11

D-88471 Laupheim

Printed in Germany

Copyright ©

Not to be reprinted, translated or duplicated either wholly or in part without written permission.

Technical details might not necessarily be exactly as described or illustrated in this operating manual.

Printed on environmentally compatible paper (bleached without chlorine, recyclable).

CONTENTS

OVERVIEW

– Abbreviations used in this manual	5
– Symbols used in this manual	5
– Description	6
 SAFETY INSTRUCTIONS	 7
– Intended use	7
– Basic rule	8
– Warning signs affixed to the equipment	8

TECHNICAL DATA

TECHNICAL DATA	10
– Fluids and lubricants	11

SAFETY

SAFETY INSTRUCTIONS FOR OPERATION	13
– Danger zone for persons	13
– Drum winch	13
– Tensile loads - upper frame	15
– Auxiliary equipment	14
 NOTES FOR THE WINCH CABLE	 16
– Winch-cable designation	16
– Winch-cable service life	16

USE

– Cockpit	19
---------------------	----

Overview

Technical Data

Safety

Use

Checks

Operation

CONTENTS

CHECKS

INSPECTIONS AND CHECKS	22
– Inspection work before operation	22
– Greasing guide roll	23

OPERATION

– Moving the vehicle into position	24
– Attaching winch cable to anchor point	25
– Checking operation of pulling-force regulator	26
– Operating the drum winch	28
– Active winch	29
– Turning the PistenBully	30
– Driving downhill	31
– Driving uphill	32
– Relieving tension on the winch cable	33
– Ceasing operation	34

STOP BUTTON	37
TILTING THE LOAD PLATFORM	38
TILTING THE WINCH BOOM.	40
INSTALLING/REMOVING THE DRUM WINCH	41



This operating manual provides information about:

- ✓ how to handle, maintain and care for your drum winch.
- ✓ important instructions concerning correct and economical operation.
- ✓ warnings so that you recognise dangers in good time and avoid them.

ABBREVIATIONS USED IN THIS MANUAL

- e.g. = for example
 M_A = tightening torque
SP no. = order number for spare part
sec. = seconds
min. = minimum

SYMBOLS USED IN THIS MANUAL



Danger:

Direct and imminent danger threatening life and limb unless appropriate precautions are taken.



WARNING!

Potentially highly dangerous situation!
Danger to life and limb unless appropriate precautions are taken.



CAUTION!

Dangerous situation!
Could lead to injury unless appropriate precautions are taken.



Important notes!
Possibility of damage to the machine or its immediate surroundings.



This symbol draws attention to practical tips

DESCRIPTION

- ✓ The drum winch is used to keep the PistenBully from slipping downhill and to assist it to climb very steep gradients.
- ✓ The drum winch is not a rescue winch.
- ✓ The PistenBully's fourth pump pressurises the hydraulic fluid for the winch drive.
- ✓ The winch is driven by the pair of multi groove drums 1.
- ✓ The windlass 2 keeps the cable under a defined tension.
- ✓ The pull on the cable can be varied by means of pulling-force regulator 3.
- ✓ Usable cable length 1000 meters.



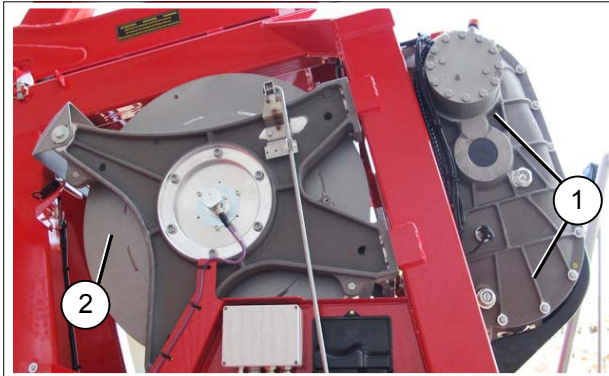

INTENDED USE

The drum winch:

- is an accessory for the PistenBully.
- must be operated on the platform of the PistenBully.

Use the drum winch only:

- to secure the PistenBully to prevent it slipping on descents.
- to assist the PistenBully when ascending steep gradients.
- when it is in perfectly safe operating condition.



If you wish to use the equipment for any other purpose, you must obtain prior written approval from the manufacturer.

BASIC RULE

Always comply with the operating instructions for the drum winch and the PistenBully.

An employee of Kässbohrer Geländefahrzeug AG or a person expressly appointed by the company has:

- commissioned the equipment.
- instructed the driver in the use of a drum winch.
- instructed the personnel for checking and maintenance work.
- When drivers change the owner-operator is responsible for providing correct and adequate instruction for the new driver.

WARNING SIGNS AFFIXED TO THE EQUIPMENT

- Strict compliance with the warning signs affixed to the drum winch is mandatory.
- Warning signs must be replaced immediately if lost or damaged.



Warning sign



Location: Winch frame

SP No. 8.762.638.058E

Rotating components can crush fingers and hands.

Keep well clear of component until it has come to a complete standstill.

Warning sign

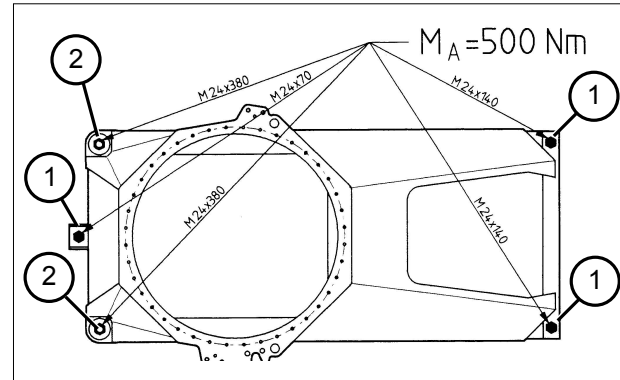

Location: Winch frame

SP No. 8.762.651.000 E

Danger: Slackening of threaded fasteners.

Always make sure that all threaded fasteners on the winch mount are tightened to their specified torques.

TECHNICAL DATA

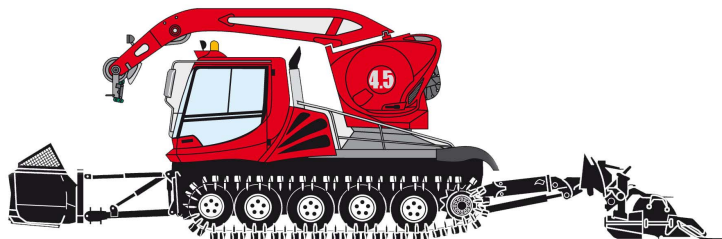

Drum winch

Type TL45 K AH 1050/11	Plumettaz
Pulling force	45 kN
Cable diameter	11 mm
Cable length	1,050 m
Usable cable length	1,000 m
Propulsive power at pulling force of 45 kN	110 kW (150 hp)

Speed

With drum winch	0 - 23 km/h
winch in operation at pulling force of 45 kN	7.5 km/h

Weight

Weight (winch, cable and mount) . . .	2,185 kg
Dead weight with combination tracks	10,575 kg
Dead weight with steel tracks	11,215 kg
Permissible total weight including auxiliary equipment	13,500 kg
2,500 kg	
Payload of load area without winch .	



Designation	Grade	Capacity	Interval
Gear oil	<p>Fully synthetic gear oil Base: Polyalphaolefin (PAO) Classification: DIN 51517 T3 CLP HC Viscosity class: ISO VG 220</p> <p>Fully synthetic gear oil Base: Polyalphaolefin (PAO) Classification: API GL 5/ MIL-L-2105 B/C Viscosity class: SAE 75W140</p>	9 litres	<p>after 100 operating hours At least: once a year every 600 hours 100/600 operating hours after W4 maintenance</p>
Windlass gear and turret-gear drive	<p>Polyalphaolefin (PAO) Classification: DIN 51517 T3 CLP HC Viscosity index: ISO VG 150 ISO VG 220 (for summer operation)</p> <p>Polyalphaolefin (PAO) Classification: API - GL 4 Viscosity class: SAE 75 W 90</p>	<p>1.1 litre</p> <p>2 x 1.7 litres turret-gear drive</p>	<p>after 100 operating hours At least: once a year every 600 hours 100 operating hours after W4 main- tenance</p>
Winch brake	<p>Engine oil MB sheet 228.5 Viscosity class: 5W40</p>	0.06 litre	<p>At least: once a year every 3000 hours</p>
Lube grease Cable guide roller / turret gear	<p>Calcium saponified grease KP 2 K-30 DIN 51502 AVIACAL 2 LD - 1kg - 0.946.047.000</p>		<p>Cable guide roll: daily Slewing gear: every 100 hours</p>
Crown gear	<p>Specification: Aluplex RHS, OGPf 0 S-20, DIN 51502</p>		<p>every 100 hours</p>
Manual pump	<p>Hydraulic fluid</p>	0.7 litre	<p>every 3000 hours</p>



NOTES

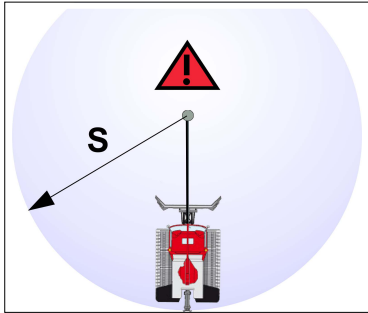

DANGER ZONE FOR PERSONS

- Risk of fatal injury:
Before using the drum winch, make sure there is no-one in the danger zone.
 - Close off the ski slope.
- Before using the drum winch, secure the danger zone "S": the size of this zone depends on the length of the cable.

DRUM WINCH

- Risk of fatal injury if cable breaks:
Operation is prohibited on slopes without sufficient flat runoff at bottom.
- Steep slopes must have sufficient runoff.
- Additional safety measures:
 - Snow wall
 - Stopper nets
 - Flashing beacons
- Note that the cable can whip over several meters as the vehicle moves over surface irregularities on the slope.
- Driving with the cable attached and the drum winch switched off is prohibited.

SAFETY INSTRUCTIONS FOR OPERATION

- Risk of collision:
Do not attempt to drive under:
 - cables
 - high-voltage electricity lines
 - drag lifts
 - cable-car runs
- The anchor point for the load hook must be rated for at least 150 kN.
- The mount for the load hook must be of non-swivel design.
- Operation of the winch is permissible only when the winch cover is closed.

AUXILIARY DRIVEN MACHINERY

The auxiliary equipment of Kässbohrer Geländefahrzeug AG has been approved for winch operation.



Risk of collision between auxiliary equipment and winch cable. Always allow adequate clearance from the winch cable when raising the auxiliary equipment.



Risk of collision between front snow blower and winch boom. The front snow blower must be suitable for a vehicle fitted with a winch.

- Use only winch cable from Kässbohrer Geländefahrzeug AG.



TENSILE LOADS - UPPER FRAME



High tensile load on the upper frame.
When PistenBully changes direction relative to the anchor point.

Change of direction up to 30° :
(winch boom / outside mirrors)

- Set pulling-force regulator to a maximum of 4 metric tons.

Change of direction more than 30° :

- Set pulling-force regulator to a maximum of 2.0 metric tons.

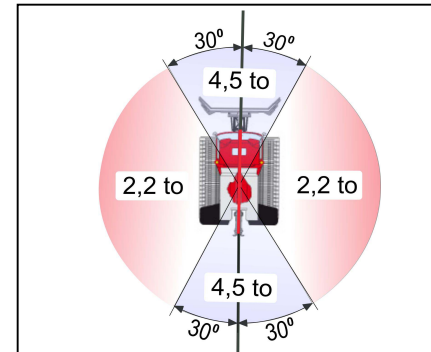

Zugkraftregelung

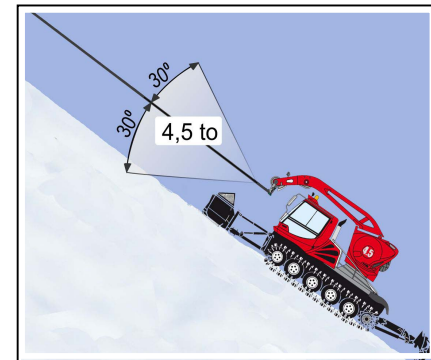

Zugkraftregelung

SAFETY INSTRUCTIONS FOR OPERATION

WINCH-CABLE DESIGNATION

Winch-cable designation:

- Winch cable \varnothing 11 mm
- Cable length 1050 metres.



Usable cable length 1000 metres.

The rest of the winch cable is marked red.

- Use only Kässbohrer winch cables.
- Always comply with all applicable national safety regulations for cable monitoring

WINCH-CABLE USABLE LIFE

Depends on:

- the load on the cable.
 - the number of turns over the drums.
 - handling and maintenance.
-
- The winch cable is maintenance-free
 - Winch cable:
 - Do not re-grease.
 - Do not apply preserving agents.
 - Do not clean with a high-pressure cleaner.
 - Use only a dry cloth to wipe off.



THE WINCH CABLE IS DUE FOR REPLACEMENT IF:

Winch-cable condition:

- 5 wires are broken over a length of 66 mm.
- 10 wires are broken over a length of 110 mm.
- one strand is broken.
- the cable is wavy (corkscrew effect).
- the cable is kinked or crushed.

Situational help

A wire is broken on the winch cable:

- Slightly raise the broken ends and bend them back and forth until they break off at the root of the strand.



Make sure that there are no projecting wires.

- Do not cut off broken wires.

WINCH CABLE



Pockets

Cause:

Over-frequent use of the same length of

cable.

Remedy:

When work is completed, unreel the entire winch cable and take the strain off it. Leave the hook attached.

Reel the cable back onto the drum with less tension.



Snags

Cause:

Incorrect unreeling of the winch cable.

Snags damage the structure of the cable, reducing the cable to a fraction of its original strength.

SAFETY INSTRUCTIONS FOR OPERATION



Slack cable

Cause:
Strain applied suddenly and then suddenly relieved.

Remedy:
When using the winch, apply strain to the cable slowly and relieve the strain slowly as well.

Cable chafing

Do not permit the winch cable to chafe against or be deflected by hard, sharp-edged obstructions (stones, ice, steel, etc.).

Corrosion

Do not treat the winch cable with or apply acids, sulphur, saline vapour or other aggressive substances.



Storage

If possible, store the winch cable in a closed room.

WINCH CABLE LOAD HOOD

Load hook

The winch cable is fitted with a load hook with safety lock. In order to help prevent the cable from unravelling, the load hook is attached to the cable without a swivel.

ANCHOR CABLE

The anchor cable (belay) is between the anchor point and the load hook of the winch cable.

- Always use a double cable or twist stopper between the anchor cable and the load hook of the winch cable.

This will prevent the winch cable from unravelling.



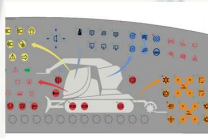

INSTRUMENT DISPLAYS20



MULTIFUNCTION JOYSTICK21



STOP BUTTON 37



TILTING THE LOAD PLATFORM39

PUSHBUTTON



Note: Pushbuttons
When the circuit is active, the indicator lights up (see arrow).



Slewing-gear holding brake
Pressed = Apply brake
Indicator lights up
Warning buzzer sounds intermittently if winch is in operation.
Pressed again = Release brake



Swivel winch boom
Top section pressed and held down = Swivel right



Bottom section pressed and held down = Swivel left



Reset acoustic warning, strand monitor



Unreel winch cable / winch operation
Top section pressed and held down for at least 2 sec. = Unreel winch cable.
Pressed again = Winch OFF



Bottom section pressed = Reel in winch cable / winch operation
Pressed again = Winch OFF



Active winch

Warning symbol lights up



Slewing-gear holding brake applied



Winch-boom warning indicator
- Winch boom not locked





Cable-winder warning indicator
- Maximum usable cable length reached.



Winch cable winding warning indicator



Winch-cable strand monitor
- Winch cable defective

- - Cease operation
- Ascertain the cause of the problem.



The winch-cable strand monitor is not a substitute for visual inspection of the winch cable.



Electronic pulling-force control is OFF
Manual pulling-force control
Comes on also if drum winch is operating in emergency mode!



Multifunction joystick
Winch pulling-force regulator
from 0 to max. 4.5 metric tons pulling force.

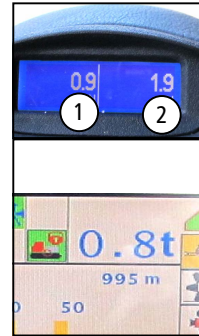

Display
- Pulling force in metric tons
- Warning indicator symbol ATTENTION
1 = Effective winch pulling force
2 = Set winch pulling force

Display on terminal
- Pulling force in metric tons.
- Winch cable length

Emergency mode, drum winch

Emergency mode is activated if a fault occurs affecting:

- Pulling-force sensor
- EP capstan motor
- Mooring valve
- CAN communication

In emergency mode

- Manual pulling-force control.
- Driving speed is reduced.

1. CHECKS BEFORE OPERATION

- Remove snow and ice from the winch.
- Check operation of slewing-gear holding brake.
- Check that hydraulic lines and connectors are free of leaks and check for chafing.
- Check that the cable guide arm moves freely on the windlass.
- Clean viewing screen for winch cable winding.



- Check operation of the safety lock
- Check ease of movement of the cable relay rollers in the winch boom and of the cable guide arm.

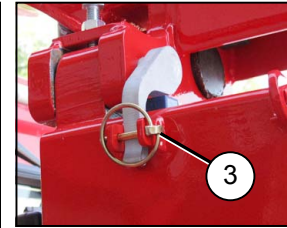
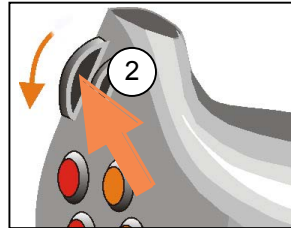

Checking winch-boom warning indicator

- Diesel-engine ignition ON.
- Turn winch pulling-force regulator 2 to 0.
- Pull pin 3 and open the toggle.



Winch-boom warning indicator lights up
- Winch boom not locked



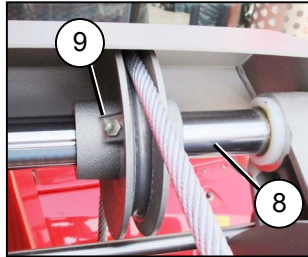

Greasing guide roll

- Grease nipple 9 and shaft 8 with special grease.

Approved special grease:

Calcium saponified grease

Specification: Aviacal 2 LD, KP2K-20 DIN 51502

Special greases are not compatible with each other.

When changing to another special grease, grease entire guide roll.

- You can now start moving the vehicle into position.

2. MOVING THE VEHICLE INTO POSITION

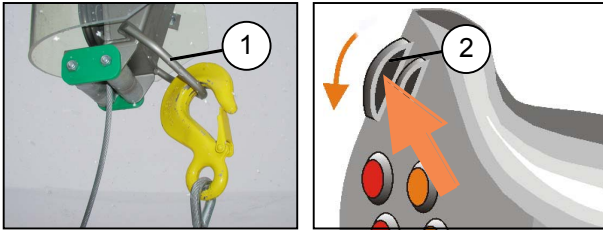

WARNING!

Make sure there is no-one in the immediate danger zone.

- Apply the parking brake.
- Engage load hook of winch cable on winch boom 1.



Make sure that load hook is engaged right way round, not turned 180°.

The safety lock could open if the hook were engaged wrong way round.



- Set winch to OFF
- Indicator light is OFF.

- Turn pulling-force regulator 2 to 0 (in direction indicated by arrow).
- Start the diesel engine.



- Swivel winch boom to side in forward direction of travel



Top section pressed and held down = Swivel right
Bottom section pressed and held down = Swivel left

- Drive the PistenBully up to the anchor point.
- Move the direction of travel switch to the neutral position.
- Apply the parking brake.
- Swivel the winch boom toward the anchor point.
The vehicle is now in position.
- You can now start attaching the winch cable to the anchor point.

3. ATTACHING WINCH CABLE TO ANCHOR POINT



- Check:
Warning light for winch boom is OFF



- Turn the pulling-force regulator to 0.



- Set the winch switch to the "unreel cable" position.
- Hold down the switch for at least 2 sec.
- Warning buzzer sounds intermittently.



The drive discs rub against the winch cable. This causes heating and accelerated wear.

Remedy: Work quickly and smoothly when engaging the winch cable.

- Disengage the load hook from the winch boom and pull it quickly to the anchor point.



- Visual inspection: The 2nd cable intake roll must also turn. Adverse weather can freeze the roll and prevent it from turning.

- Secure the load hook to the anchor point.



- Set winch to OFF
- Indicator light is OFF.

- You can now proceed to the function check of the pulling-force regulator.

4. FUNCTION CHECK OF PULLING-FORCE REGULATOR



High load on winch boom.

Keep far enough away from the anchor point to ensure that the high pulling force does not draw the winch boom down or up.

- Check:
The pulling-force regulator must be at 0, otherwise the cable cannot be reeled in.



- Set the switch to the "reel in cable" position.



- Slewing-gear holding brake releases as soon as the winch is set to the "reel in cable" position.



- The indicator light comes on
 - Electronic pulling-force control is OFF
 - Warning buzzer sounds



- Slowly turn the pulling-force regulator in the direction indicated by the arrow until the cable is reeled in.
- Continue turning the pulling-force control to a maximum of 0.5 metric ton (see Indicator, display steering wheel or terminal)
 - The winch cable is tensioned.



- Turn the pulling-force regulator slowly in the direction indicated by the arrow past the 1.8 metric tons position.





- The indicator light is OFF.
Electronic pulling-force control can be adjusted from about 0.8 metric tons to 4.5 metric tons.
- Slowly turn the pulling-force regulator to its limit stop.
- Pulling-force indicator must show 4.2 to 4.5 metric tons.
- Turn the pulling-force regulator to 0. Pulling force is reduced only to a minimum of 0.8 metric tons.



- The indicator light is OFF
- Electronic pulling-force control

This completes the function test of the pulling-force regulator.

- You can now start operating the drum winch.

Situational help



- The pulling-force regulator is turned in the direction indicated by the arrow and pulling force does not increase past 1.0 metric ton.
 - Indicator light comes on
 - Manual pulling-force control

Fault:

Pulling-force regulator was turned too quickly from 0 to more than 1.8 metric tons.

Remedy:

- Slowing turn pulling-force regulator to 0.
- Slowing turn pulling-force regulator past 1.8 metric tons.
 - Indicator lights is OFF
 - Electronic pulling-force control

Terminating electronic pulling-force control



- Turn the pulling-force regulator to 0.
- Switch the winch OFF

5. OPERATING THE DRUM WINCH



- Buckle the safety belt and operate the rocker switch to engage the electrically operated latch.



The safety belt does not provide protection unless the electrically operated latch is engaged.

- Buckle the passenger's safety belt.
- Release the parking brake.
- Set the direction-of-travel switch to "forward".



- Check: The indicator light is OFF.
- Use the accelerator pedal to control your speed.
- Set pulling-force control to between 1.0 and max. 4.5 metric tons.



If the slope is not particularly steep, reduce pulling force to minimise wear and tear on the drum winch.

Situational help

The diesel engine suddenly STOPS
- Warning buzzer sounds

- Apply the parking brake.
- Switch the winch OFF.
- Start the diesel engine.



Driving with active winch

Optional extra

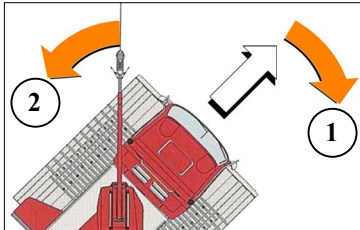

When to switch on the active winch:

The PistenBully drifts off-line when crossing a steep slope.

Example:

Driving forward and steering to right 1

Winch-boom lateral pulling force 2 activated in direction indicated by arrow. The PistenBully turns more easily and holds its heading.

Switching on the active winch function



Active winch ON / OFF

- Press button
- Indicator lights up



Display on terminal
Active winch switched on



Active winch function available only in combination with electronic pulling-force control.



The winch's lateral pulling force depends on the steering angle and the pulling force of the winch.



To help prevent overstraining the winch boom it is advisable to turn the PistenBully and switch off the active winch.

TURNING THE PISTENBULLY



Risk of collision between auxiliary equipment and winch cable. Always allow adequate clearance from the winch cable when raising the auxiliary equipment.

Turning the PistenBully

- Lift the auxiliary equipment.
- Turn the pulling-force regulator to 0 (approx. 0.8 metric tons)



– The indicator light is OFF
Electronic pulling-force control is ON.

- Turn the PistenBully and start driving downhill.

.....

Situational help

The winch cable is swinging:

- Do not drive when the winch cable is swinging.

The boom deflects the winch cable:

- Check the slewing-gear holding brake.



DRIVING DOWNHILL

Note the following for driving downhill:

- Usable winch-cable length 1000 metres.

Excess cable past 1000 metres:

- The excess winch cable is marked red
- Warning buzzer sounds



- Warning light for cable-winder monitor lights up

**Danger:**

The end of the winch cable is not secured to the winch. If the warning buzzer sounds and the warning indicator lights up:

Immediately stop or turn the PistenBully.
Check winch-cable winding.

Driving downhill

- Set pulling-force control to between 0.8 and max. 4.5 metric tons.



If the slope is not particularly steep, reduce pulling force to minimise wear and tear on the drum winch.

Situational help

The pulling force of the drum winch increases when you drive downhill:

- Use the potentiometer to reduce driving speed.

Warning light for cable-winder monitor flashes

- Immediately bring the vehicle to a standstill.
- Check winch-cable winding.

DRIVING UPHILL



High load on winch boom.

Do not approach too close to the anchor point: keep far enough away to ensure that the high pulling force does not draw the winch boom down or up.



Risk of collision between winch cable and PistenBully.
Make sure that the cable always remains taut when it is being reeled in.

Use the speed potentiometer to reduce speed on level ground.
Keep engine rpm constant.

Driving uphill

- Increase pulling force to between 0.8 and max. 4.5 metric tons, as necessary.
- If the slope is not particularly steep, reduce pulling force to minimise wear and tear on the drum winch.



Adjust the pulling-force regulator to a setting at which the tracks do not lose traction.

- Check that the winch cable is reeling in correctly onto the reel.
You can watch the cable reeling onto the reel through the viewing window on the drum winch.



Situational help

Warning light for winch-cable strand monitor lights up:



Winch-cable strand monitor
- Winch cable defective

- Immediately bring the vehicle to a standstill.
- Direction of travel switch in neutral position.
- Apply the parking brake.
- Check the winch cable on the drum.

Situational help

Pulling force decreases:

- Use the potentiometer to reduce driving speed.
Keep engine rpm constant.

RELIEVING TENSION ON THE WINCH CABLE



Relieve the tension on the winch cable before ceasing operations.

- Unreel the winch cable as far as the red mark.



If the terrain does not permit the cable to be unreeled to full usable length:

- Unreel at least 10 metres more of the winch cable than was used under working conditions.

- Lay the cable on the ground and check for twist.
(see customer's workshop information)
- Use a low pulling-force setting to reel in the cable and check it for damage.

CEASING OPERATION

- Drive the PistenBully up as close as possible to the anchor point.
- Drop the front blade.



- Set the slewing-gear holding brake to "applied". Warning buzzer sounds intermittently.



- The indicator light is ON.



- Back off the pulling-force regulator as far as it will go.

- Apply the parking brake.



- Set the winch switch to the "unreel cable" position.

Hold the button down for at least 2 seconds.
Warning buzzer sounds intermittently

- Disengage the load hook from the anchor point.



Risk of damage due to cable unravelling

Secure the winch cable by suitable means (e.g. rod) to ensure that the strands cannot unravel.



- Set the switch to the "reel in cable" position. Warning buzzer for slewing-gear holding brake sounds intermittently, 3x short buzzes.



WARNING!

Risk of accident:

- Make sure there is no-one in the danger zone as the cable is being reeled in.
- Do not leave the cockpit.



- Reel the cable onto the drum at low pulling force.





- Back off the pulling-force regulator as far as it will go.



- Set the switch to the "neutral" position.
- The indicator light is OFF.



- Swivel winch boom to side in forward direction of travel



Top section pressed and held down = Swivel right



Bottom section pressed and held down = Swivel left



- Secure the load hook to the winch boom.



NOTES



Hit the STOP switch:

- if a dangerous situation arises.

The PistenBully comes to an immediate stop and will not answer to the steering.

- Immediately apply the parking brake.
- Switch off the diesel engine.
- Check the drum winch and rectify the fault.



A stop places a severe strain on the brakes of the drum winch.

- Have the brakes checked for wear and to ensure that they are in full working order.



Driving with the cable attached and the drum winch switched off is prohibited.

Operating the drum winch after a stop

- Start the diesel engine.



- Press the stop pushbutton and hold it down for 5 seconds.
The indicator light goes OUT.



- Set the pulling-force regulator to 0.



- Set the switch to the "reel in cable" position.
Warning buzzer for slewing-gear holding brake sounds intermittently, 3x short buzzes.



- Slewing-gear holding brake releases as soon as the winch is set to the "reel in cable" position.
- Release the parking brake.
- Operate the direction-of-travel switch.

The drum winch is again ready for operation.



Tilting the load platform



Risk of PistenBully slipping:

Do not tilt the winch unless the vehicle is on level ground.

Make sure there is no-one in the danger zone.

- Apply the parking brake.
- Start the diesel engine.
- Lower the auxiliary equipment, if fitted.



- Swivel the winch boom to the rear.

Top section pressed and held down = Swivel right

Bottom section pressed and held down = Swivel left

- Switch off the diesel engine.

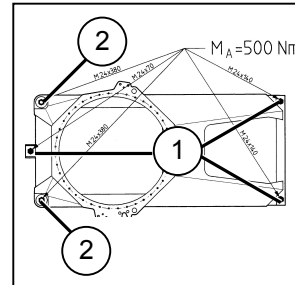

- Check that screws 1 are secure.
Tightening torque $M_A = 500 \text{ Nm}$.
- Remove screws 2.
- Tilt the load platform: See the operating manual for the PistenBully.
- When the load platform has been returned to its lowered position, tighten screws 2 to the specified tightening torque $M_A = 500 \text{ Nm}$.

Tilting the winch boom

WARNING!

Make sure there is no-one in the danger zone.

- Apply the parking brake.
- Start the diesel engine.
- Lower the auxiliary equipment, if fitted.
- Set the pulling-force regulator to 0.
- Switch the winch OFF.



The winch boom will collide with the driver's cab if it is tilted when swivelled forward.



- Swivel winch boom to side in forward direction of travel



Top section pressed and held down = Swivel right
Bottom section pressed and held down = Swivel left

- Switch off the diesel engine.



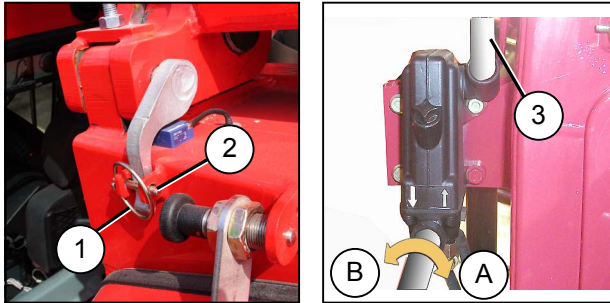

Using manual pump to tilt winch boom:

- Pull out keeper 1 and release pin 2.
- Turn the manual pump lever to position B.
- Fit tube 3 and operate the manual pump.

Using manual pump to raise winch boom:

- Turn the manual pump lever to position A.
- Fit tube 3 and operate the manual pump.

Removing drum winch

WARNING!

Make sure there is no-one in the danger zone.

- Park the PistenBully underneath a crane.
Rated lifting capacity of crane min. 2 metric tons and min. 50 cm lift.
Comply with all applicable national regulations.
- Apply the parking brake.
- Start the diesel engine.
- Lower the auxiliary equipment, if fitted.
- Swivel the winch boom to the rear.
- Switch off the diesel engine.
- Disconnect the hydraulic lines.
- Disconnect the electrical connection.

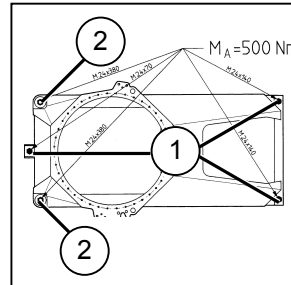

- Fit protective caps.
- Attach the crane slings to the drum winch.
- Remove screws 1 and 2.
- Remove the drum winch.
- Tighten screws 1 and 2 in the load platform.
- Fit the cover plate onto the upper frame.
- Place the winch in storage in the correct manner.
- Install the retaining bar.



Installing drum winch

- Lower the auxiliary equipment, if fitted.
- Switch off the diesel engine.
- Remove the cover plate from the upper frame.
- Remove the retaining bar.
- Lower the drum winch onto the guide points on the load platform.
- Install screws 1 and 2 and tighten to the specified tightening torque $M_A = 500 \text{ Nm}$.
- Disengage the crane slings from the drum winch.
- Connect the hydraulic lines.
Connect the leak-off oil line first.

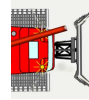

- Swivel the winch boom sideways in the direction of travel.



Make sure that the hydraulic couplings are secure.

- Connect the electric connector.
- Apply the parking brake.
- Start the diesel engine.



KÄSSBOHRER GELÄNDEFahrZEUG AG



Dieser Betrieb ist ISO 14001
und ISO 9001 zertifiziert