

grande
brio
35 B & E



PERFETTA
PER PICCOLI **AMBIENTI**

PERFECT
FOR SMALL **AREAS**

INNOVATION IN CLEANING EQUIPMENT
TSM

grande brio

35 B & E

35 B

35 E

Pista di pulizia / Scrubbing path	mm	350	350
Larghezza tergipavimento / Squeegee width	mm	420	420
Rendimento orario / Coverage performance	m ² /h	1050	1050
Tempo di lavoro / Working time	h	> 1h 30'	∞
Serbatoio soluzione / Solution tank	l	16	16
Serbatoio recupero / Recovery tank	l	18	18
Diametro spazzole / Brush size	mm	1 x 350	1 x 350
Motore spazzole / Brush motor	W	1 x 250	1 x 250
Pressione spazzola / Brush pressure	kg	28	28
Motore trazione / Traction motor	W	//	//
Motore aspirazione / Vacuum motor	W	2 stages periph. 200	2 stages periph. 210
Tensione di alimentazione / Voltage	V	12	220
Batterie (DIN) / Battery capacity (DIN)	A (5h)	65 (Agm)	//
Comparto batterie (LxLxH) / Batt. comp. (LxWxH)	mm	290 x 190 x 235	//
Caricabatterie a bordo / On board battery charger	A/h	8	//
Peso senza (con) batterie / Weight without (with) batteries	kg	40 / {63,5}	40,5
Dimensioni (LxLxH) / Dimensions (LxWxH)	mm	770 x 460 x 645	770 x 460 x 645



Immediata Immediate
Efficace Effective
Ergonomica Ergonomic
Compatta Compact
Semplice Easy

grande
brio
35 B & E

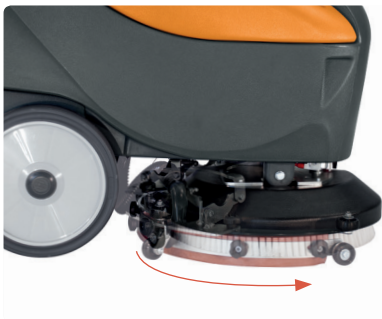

It's time to step forward and face the world's challenge.
It's time for GRANDE BRIO

The conquest of simplicity



TSM - Technological Systems by Moro Srl

Via Fratelli Zambon, 9 - 33080 Fiume Veneto (PN) - Italy

Tel. +39.0434.564167 - Fax +39.0434.954069

www.tsmitaly.com - marketing@tsmitaly.com

 - [tsmitaly](https://www.youtube.com/tsmitaly) -

